

**User Manual**  
**8020**  
**20 MHz Programmable**  
**Function Generator**

Serial Prefix: 70



*Tabor Electronics Ltd.*

9 Hatasia Street, Tel Hanan, Israel 20302  
TEL: (972) 4 821 3393, FAX: (972) 4 821 3388  
[[www.taborelec.com](http://www.taborelec.com)]

---

**PUBLICATION DATE: July 18, 2001**

**REVISION: B**

Copyright 2001 by Tabor Electronics. All rights reserved. This book or parts thereof may not be reproduced in any form without written permission of the publisher.

# Warranty

---

Tabor Electronics' products are warranted against defects in material and workmanship, when used under normal operating conditions, for a period of one year after delivery. Tabor Electronics will repair or replace without charge any product which proves defective during this period. Repair necessitated by misuse of the product is not covered by this warranty. No other warranties are expressed or implied, including but not limited to the implied warranties of merchantability and fitness for a particular purpose. Tabor Electronics is not liable for consequential damage.

## **REPAIR AND CALIBRATION**

Prior authorization is required from Tabor Electronics before products are returned for service. All service must be performed by Tabor Electronics' factory or an authorized service center. Please contact the factory directly for repair and re-calibration:

Tabor Electronics, Ltd.  
9 Hatasia Street  
Tel Hanan, Israel 20302  
Tel: 972-4-821-3393  
Fax: 972-4-821-3388

**REPAIR AND CALIBRATION REQUEST FORM**

To allow us to better understand your repair requests, we suggest you use the following outline when calling and include a copy with your instrument to be sent to the Tabor Repair Facility.

Model \_\_\_\_\_ Serial No. \_\_\_\_\_ Date \_\_\_\_\_

Company Name \_\_\_\_\_ Purchase Order # \_\_\_\_\_

Billing Address \_\_\_\_\_

City

State/Province

Zip/Postal Code

Country

Shipping Address \_\_\_\_\_

City

State/Province

Zip/Postal Code

Country

Technical Contact \_\_\_\_\_ Phone Number ( ) \_\_\_\_\_

Purchasing Contact \_\_\_\_\_ Phone Number ( ) \_\_\_\_\_

1. Describe, in detail, the problem and symptoms you are having. Please include all set up details, such as input/output levels, frequencies, waveform details, etc.

---

---

---

---

2. If problem is occurring when unit is in remote, please list the program strings used and the controller type.

---

---

---

3. Please give any additional information you feel would be beneficial in facilitating a faster repair time (i.e., modifications, etc.)

---

---

---

4. Is calibration data required?      Yes    No    (please circle one)

Call before shipping

Note: We do not accept  
"collect" shipments.

Ship instruments to nearest support office  
listed on back.

# Safety Precautions

---

The following safety precautions should be observed before using this product and associated computer. Although some instruments and accessories would normally be used with non-hazardous voltages, there are situations where hazardous conditions may be present. This product is intended for use by qualified personnel who recognize shock hazards and are familiar with the safety precautions required to avoid possible injury. Read the operating information carefully before using the product. Exercise extreme caution when a shock hazard is present. Lethal voltage may be present on cables, connector jacks, or test fixtures.

The American National Standard Institute (ANSI) states that a shock hazard exists when voltage levels greater than 30V RMS, 42.4V peak, or 60 VDC are present. A good safety practice is to expect that hazardous voltage is present in any unknown circuit before touching or disconnecting the line cord. Before operating an instrument, make sure the line cord is connected to a properly grounded power receptacle. Inspect the connecting cables and test leads for possible wear, cracks, or breaks before each use.

For maximum safety, do not touch the product, test cables, or any other of the instrument parts while power is applied to the circuit under test. ALWAYS remove power from the entire test system before connecting cables or jumpers, installing or removing cards from the computer, or making internal changes, such as changing card address. Do not touch any object that could provide a current path to the common side of the circuit under test or power line (earth) ground. Always keep dry hands while handling the instrument. If you are using test fixtures, keep the lid closed while power is applied to the device under test. Safe operation requires that the computer lid be closed at all times during operation.

Carefully read the Safety Precautions instructions that are supplied with your computer. Instruments, cables, leads or cords should not be connected to humans. Before performing any maintenance, disconnect the line cord and all test cables. Finally, maintenance should be performed by qualified service personnel only. If you have no past experience in instrument servicing, we strongly recommend that installation and initial tests on the instrument be done by your dealer or by the factory itself.

# DECLARATION OF CONFORMITY

We: Tabor Electronics Ltd.  
9 Hatasia Street, Tel Hanan  
ISRAEL 20302

declare, that the 50 MHz Pulse/Function Generators

## Model 8020 and Model 8021

meet the intent of Directive 89/336/EEC for Electromagnetic Compatibility and complies with the requirements of the Low Voltage Directive 73/23/EEC. Compliance was demonstrated to the following specifications as listed in the official Journal of the European Communities:

### **Safety:**

EN 61010-1

IEC 1010-1 (1990) + Amendment 1 (1992)

### **EMC:**

EN 50081-1 Emissions:

EN 55022 - Radiated, Class B

EN 55022 - Conducted, Class B

EN 50082-1 Immunity:

IEC 801-2 (1991) - Electrostatic Discharge

IEC 801-3 / ENV50140 (1993) - RF Radiated

IEC 801-4 (1991) - Fast Transients

Model 8020 and Model 8021 were tested in typical configuration.

---



---

## TABLE OF CONTENTS

### SECTION 1. GENERAL INFORMATION

1-1	Introduction	1-1
1-2	Description	1-1
1-3	Instrument and Manual Identification	1-2
1-4	Options	1-2
1-5	Specifications	1-2
1-6	Safety Consideration	1-2
1-7	Accessories Supplied	1-2

### SECTION 2. INSTALLATION

2-1	Introduction	2-1
2-2	Unpacking and Initial Inspection	2-1
2-3	Performance Checks	2-1
2-3	Power Requirements	2-1
2-5	Grounding Requirements	2-1
2-6	Installation and Mounting	2-2
2-7	Bench Operation	2-2
2-8	Rack Mounting	2-2
2-9	Portable Use	2-2
2-10	Short Term Storage	2-2
2-11	Long Term Storage or Repacking for Shipment	2-2
2-12	Safety	2-3

### SECTION 3. OPERATION

3-1	Introduction	3-1
3-2	Front Panel Familiarization	3-1
3-2-1	Controls	3-1
3-2-1-1	Status	3-1
3-2-1-2	Display/Modify	3-1
3-2-1-3	Trigger Mode	3-3
3-2-1-4	Operating Mode	3-3
3-2-1-5	Output	3-3
3-2-1-6	Modifier	3-3
3-2-2	Connectors	3-3
3-2-3	Display And Indicators	3-4

3-3	Rear Panel Familiarization	3-4
3-3-1	Connectors and Switches	3-4
3-4	Power-up Procedure	3-4
3-5	Software Reset	3-5
3-5-1	Parameter Preset	3-5
3-6	Display Messages	3-6
3-7	Detecting Programming Errors	3-6
3-7-1	General Error	3-6
3-7-2	Pulse/Ramp Set-up Errors (model 8021 only)	3-6
3-7-3	Offset Errors	3-6
3-7-4	IEEE-488 Errors	3-7
3-8	Selecting 2nd Functions	3-7
3-9	Modifying Parameters	3-7
3-9-1	Modifier	3-8
3-9-2	Range	3-8
3-9-3	Parameter Limits	3-8
3-10	Selecting an Output Waveform	3-9
3-11	Disabling The Output	3-9
3-12	Selecting an Operating Mode	3-9
3-12-1	Function Generator Mode	3-9
3-12-2	Sweep Generator Mode	3-9
3-12-2-1	Selecting Sweep Direction	3-9
3-12-3	Voltage Controlled Oscillator Mode	3-10
3-12-4	Pulse Generator Mode (model 8021 only)	3-10
3-12-5	AM Mode (model 8022 only)	3-11
3-13	Triggering The Pulse Generator	3-11
3-14	Using Front Panel Set-ups	3-11
3-14-1	Store Set-ups	3-11
3-14-2	Recall Set-ups	3-12
3-14-2-1	Using The Recall Mode	3-12
3-15	Using The Offset	3-12
3-16	Changing The GPIB Address	3-12

#### **SECTION 4. IEEE PROGRAMMING**

4-1	Introduction	4-1
4-2	Bus Description	4-1
4-3	IEEE-488 Bus Lines	4-2
4-3-1	Bus Management Lines	4-2
4-3-2	Handshake Lines	4-2
4-3-3	Data Lines	4-3
4-4	Interface Function Codes	4-3
4-5	Software Considerations	4-4
4-6	Hardware Consideration	4-4

4-6-1	Typical Controlled Systems	4-4
4-6-2	Connections	4-5
4-7	Changing GPIB Address	4-5
4-8	Bus Commands	4-5
4-8-1	Uniline Commands	4-6
4-8-2	Universal Multiline Commands	4-7
4-8-3	Addressed Commands	4-8
4-8-4	Unaddress Commands	4-9
4-8-5	Device Dependent Commands	4-9
4-8-6	Common Commands and Queries	4-9
4-9	Device Listing Formats	4-9
4-9-1	Function Element Summary	4-10
4-9-2	Seperator Function Element Summary	4-10
4-9-2-1	Program Message Unit Seperator	4-10
4-9-2-2	Program Data Seperator	4-10
4-9-2-3	Program Header Seperator	4-10
4-9-3	Program Message Terminator	4-11
4-9-4	Command Program Header	4-11
4-9-5	Query Program Header	4-11
4-9-6	Program Data	4-11
4-9-6-1	Character Program Data	4-11
4-9-6-2	Decimal Numeric Program Data	4-11
4-9-6-3	Suffix Program Data	4-12
4-9-6-4	Non-Decimal Program Data	4-12
4-9-6-5	Arbitrary Block Program Data	4-12
4-9-6-6	Expression Program Data	4-12
4-10	Device-Dependent Command Programming	4-12
4-10-1	Display Modify (D)	4-12
4-10-2	Operating Mode (P, V, A, O)	4-16
4-10-3	Trigger Mode (G, T)	4-16
4-10-4	Output Mode (C, B)	4-16
4-10-5	Waveform (U)	4-16
4-10-6	Parameter Programming	4-16
4-10-7	Common Commands	4-17
4-10-7-1	Set-ups (*SAV, *RCL)	4-18
4-11	Device Talking Formats	4-18
4-11-1	Function Element Summary	4-19
4-11-2	Seperator Function Element Summary	4-19
4-11-2-1	Response Message Unit Seperator	4-19
4-11-2-2	Response Data Seperator	4-19
4-11-2-3	Response Header Seperator	4-19
4-11-3	Response Message Terminator	4-19
4-11-4	Response Header	4-20
4-11-5	Response Data	4-20



4-11-5-1	Character Response Data	4-20
4-11-5-2	Decimal Numeric Response Data	4-20
4-12	Reading From the Model 8020	4-20
4-12-1	Interrogate Parameter Data Query	4-21
4-12-2	Common Queries	4-21
4-12-3	Response Header (X)	4-21
4-12-4	Response Message Terminator	4-22
4-13	Device Status Reporting	4-22
4-14	Status Byte Register	4-22
4-14-1	Reading the Status Byte Register	4-23
4-14-1-1	Reading with a Serial Poll	4-23
4-14-1-2	Reading with the *STB?	4-23
4-14-1-3	Clearing the Status Byte Register	4-23
4-14-1-4	Service Request Enable Register	4-23
4-14-2	Standard Event Status Register (ESR)	4-24
4-14-2-1	Standard Event Status Register (ESE)	4-24
4-14-3	Machine Status Register (STT)	4-26
4-15	Front Panel Error Messages	4-26
4-15-1	ILI (Illegal Instruction) Error	4-26
4-15-2	ILP (Illegal Parameter) Error	4-26

## SECTION 5. MAINTENANCE AND PERFORMANCE CHECKS

5-1	Introduction	5-1
5-2	Line Voltage Selection	5-1
5-3	Fuse Replacement	5-1
5-4	GPIB Interface Option Field Installation (option 1)	5-1
5-4-1	Option 1 Installation Procedure	5-2
5-5	Disassembly Instructions	5-2
5-6	Special Handling Of Static Sensitive Devices	5-3
5-7	Cleaning	5-3
5-8	Repair and Replacement	5-3
5-9	Performance Checks	5-3
5-9-1	Environmental Conditions	5-3
5-9-2	Warm-up Period	5-3
5-9-3	Recommended Test Equipment	5-3
5-10	Performance Checks Procedure	5-4
5-10-1	Frequency - Gated Mode	5-4
5-10-2	Frequency - Continuous Mode	5-4
5-10-3	Amplitude	5-5
5-10-4	DC Characteristics	5-5
5-10-5	Squarewave Characteristics	5-5
5-10-6	Sine Characteristics	5-5

5-10-7	Sine Flatness	5-6
5-10-8	Trigger, Gate, Manual	5-6
5-10-9	Sweep	5-6
5-10-10	VCO Control	5-7
5-10-11	Pulse Width (model 8021)	5-7
5-10-12	Amplitude Modulation (model 8022)	5-8

## SECTION 6. THEORY OF OPERATION

6-1	Introduction	6-1
6-2	Overall Functional Description	6-1
6-3	Analog Circuitry	6-1
6-3-1	Current Generator	6-1
6-3-2	Voltage controlled Oscillator	6-3
6-3-3	Sine Shaper	6-4
6-3-4	Trigger Circuit	6-4
6-3-5	Pulse Shaper	6-6
6-3-6	Preamplifier	6-7
6-3-7	Attenuator	6-7
6-3-8	Offset Generator	6-7
6-3-9	Power Amplifier	6-7
6-3-10	Post Amplifier Attenuator	6-7
6-3-11	Power Supply	6-7
6-4	Pulse Generator Circuit (model 8021)	6-7
6-5	AM Circuit (model 8022)	6-9
6-6	Digital Circuitry	6-9
6-6-1	Display and Keyboard Interface	6-9
6-6-2	Counter Circuit	6-10
6-6-3	IEEE-488 Interface (Option 1)	6-10

## SECTION 7. ADJUSTMENTS

7-1	Introduction	7-1
7-2	Adjustments	7-1
7-2-1	Environmental Conditions	7-1
7-2-2	Warm-up Period	7-1
7-2-3	Recommended Test Equipment	7-1
7-2-4	Adjustment Procedures	7-1
7-3	Adjustment Procedure	7-2
7-3-1	Power Supply Adjustment	7-2
7-3-2	Distortion Adjustment	7-2
7-3-3	Frequency Adjustment	7-2
7-3-4	Low Frequency Adjustment	7-2
7-3-5	Low Frequency Distortion Adjustment	7-2

7-3-6	Trigger Start Phase Adjustment	7-3
7-3-7	Amplitude Adjustment	7-3
7-3-8	Offset Adjustment	7-3
7-3-9	Squarewave Response Adjustment	7-3
7-3-10	Sine Flatness Adjustment	7-3
7-3-11	Triangle Flatness Adjustment	7-4
7-3-12	Reference Oscillator Adjustment	7-4
7-3-13	Pulse Width Adjustment (model 8021 only)	7-4
7-3-14	Ramp Amplitude Adjustment (model 8021 only)	7-4
7-3-15	Amplitude Modulation Adjustment	7-4

## SECTION 8. PARTS LIST

8-1	General	8-1
8-2	Ordering Information	8-1
8-3	Maintenance Kit	8-1
8-4	Parts Description	8-1

## SECTION 9. SCHEMATIC DIAGRAMS

### LIST OF TABLES

1-1	Model 8020 Specifications	1-3
3-1	Default State After Software Reset	3-5
3-2	Offset Amplitude Programming Limits	3-7
3-3	Front Panel Parameter Entry Limits	3-8
4-1	Model 8020 Interface Function Codes	4-4
4-2	IEEE contact Designation	4-5
4-3	IEEE-488 Bus Command Summary	4-6
4-4	Default conditions. (Status after SDC or DCL)	4-8
4-5	Device Dependent Command Summary	4-10
4-6	SRQ Mask Commands	4-13
4-7	SRQ Mask Legal Commands	4-13
5-1	Line Fuse Selection	5-1
5-2	Required Test Equipment	5-4
8-1	Model 8020 Parts List - Main Board assembly	8-1
8-2	Model 8020 Parts List - Final Amplifier Board Assembly	8-4
8-3	Model 8020 Parts List - Front Panel Board Assembly	8-7
8-4	Model 8021 Parts List - Pulse Generator Board Assembly	8-7
8-5	Model 8022 Parts List - AM Generator Board Assembly	8-8

**LIST OF FIGURES**

2-1	Model 8020- Outline Dimensions	2-3
3-1	Front Panel Controls, Indicators and Connectors	3-2
4-1	IEEE Bus Configuration	4-2
4-2	IEEE Handshake Sequence	4-3
4-3	IEEE-488.2 Status Reporting Model	4-25
5-1	GPIB Interface Option Installation	5-2
6-1	Model 8020- Simplified Block Diagram	6-2
6-2	Current Generator Simplified Block Diagram	6-3
6-3	VCO Simplified Block Diagram	6-4
6-4	Model 8020 - Clamp Circuit Simplified Diagram	6-5
6-5	Model 8020 - Clamp Circuit Waveform (Triggered Mode)	6-5
6-6	Model 8020 - Clamp Circuit Waveform (Gated Mode)	6-6
6-7	Pulse Generator Functional Block Diagram	6-8
6-8	AM Functional Block Diagram	6-9

This page was intentionally left blank

## SECTION 1

### GENERAL INFORMATION

#### 1-1. INTRODUCTION

This manual provides operation and maintenance information for the Model 8020 Function Generator. Section 1 is a general description of the Model 8020. Sections 2 and 3 contain installation and operation instructions. IEEE programming is explained in Section 4. Maintenance and performance checks are provided in section 5. The theory of operation is described in section 6. Section 7 outlines calibration and troubleshooting procedure. Section 8 contain tables of replaceable parts and recommended spare parts. Section 9 contains schematic and component location diagrams.

#### 1-2. DESCRIPTION

Model 8020 is a high performance - digital function generator. It provides a variety of signal waveforms, for use as test stimuli to many different electronic devices. Micro-processor based, Model 8020 is extremely easy to set up for manual use as well as simple to program in an IEEE-488 GPIB system environment. The generator features as standard: lin/log sweep, pulse waveforms and complete triggering facilities - including internal trigger generator.

Model 8020 provides a wide frequency coverage and a large amplitude span; ensuring continuing usefulness for a variety of tasks, today as well as in the future, when demands change. Rapid, repeatable testing every time is assured by thirty non-volatile stored set-ups thus, ensuring exact duplication of previous set-ups no matter how complex is assured. Its performance, programmability and economy make it equally at home in every laboratory.

Output may be selected to be either continuous, gated or triggered. The function generator features a built-in trigger generator which can replace an external triggering device. Additional convenience is achieved through the MANUAL button permitting user control over triggering sequences.

Alternately, model 8020 may also be used as an independent sweep generator with its output signal swept over an exceptionally wide range of 10 decades. A choice of eight sweep modes, both linear and logarithmic, covers most applications which are known today. A MARKER output is provided to permit Z-axis modulation of an oscilloscope to intensify parts of the scope trace.

Output level ranges from 20 mV to 30 Vp-p into open circuit or 10 mV to 15 Vp-p into 50 ohms. Maximum DC offset plus AC signal is variable within a window level from -15 V to +15 V into open circuit or from -7.5 V to +7.5 V into 50 ohms.

The function generator employs a built-in counter. This counter is not available to the outside world however, it is incorporated in an internal loop which automatically monitors the output frequency. When a deviation of more than a few tenth of a percent is detected by the counter, the frequency is automatically corrected by the internal microprocessor.

There are two other models which will be described in this manual:

**Model 8021 - 20 MHz Pulse/Function Generator.** This instrument is identical in its basic functions to the Model 8020. In addition, this instrument offers Pulse and Ramp capabilities. Pulse width and ramp width ranges are controllable within a range of 25.0 nS to 9.99 S. Pulse complement and inverted ramp functions are also available.

**Model 8022 - 20MHz AM Function Generator.** This model offers an amplitude modulation function in addition to the 8020 functions. Carrier level is controllable within the range of 0 to 100 %. Modulating signal is applied through a front panel BNC connector. The operator may select as a carrier any of the standard available functions.

**NOTE**

This manual provides a complete description of all features of the 8020 series. Therefore, several of the features which are described in the following paragraphs may not be installed in your instrument.

**1-3. INSTRUMENT & MANUAL IDENTIFICATION**

The serial number of the instrument is located on the rear panel of the instrument. The two most significant digits identify instrument modifications. If this prefix differs from that listed on the title page of this manual, there are differences between this manual and your instrument.

Technical corrections to this manual (if any) are listed in the back of this manual on an enclosed MANUAL CHANGES sheet.

**1-4. OPTIONS**

Model 8020 offers a GPIB interface bus option; designated as OPTION 1.

Option 1 is field installable or may be ordered with new instruments from the factory. Installation procedures are given in Section 6 of this manual. There are no software modifications necessary when installing the option. The instrument will automatically sense the presence of the newly installed interface and will then permit operation through the IEEE-488 GPIB interface.

**1-5. SPECIFICATIONS**

Instrument specifications are listed in Tables 1-1. These specifications are the performance standards or limits against which the instrument is tested.

**NOTE**

All specifications in the following table apply with output terminated with 50 feedthrough termination and with an amplitude of 15Vp-p. Warm-up period is 30 min at an ambient temperature of 25 +/-5 deg C.

**1-6. SAFETY CONSIDERATIONS**

Model 8020 is a Safety Class 1 instrument with an exposed metal chassis that is directly connected to earth via the power supply cable and has been manufactured according to international safety standards. Before the instrument is switched on, make sure that protective earth terminal is connected to a protective earth via the power cord. Do not remove instrument covers when operating or when power cord is connected to mains.

Any adjustment, maintenance and repair of the opened instrument under voltage should be avoided as much as possible, but when inevitable, should be carried out only by a skilled person who is aware of the hazard involved.

**1-7. ACCESSORIES SUPPLIED**

The 8020 is supplied with ac power cord and with an instruction manual. Extra manual is available on request.

Table 1-1. Model 8020 Specifications

<b>WAVEFORMS:</b>	Sine, Triangle, Square, Positive Pulse, Negative Pulse, TTL Pulse (SYNC out), DC		
<b>FREQUENCY CHARACTERISTICS</b>			
Range:	2 mHz to 20 MHz		
Resolution:	3 1/2 digits (2000 counts max) with exponent		
Accuracy:	Continuous: +/-3 % of full scale from 2 mHz to 9.99 Hz; .1 % of full scale from 10 Hz to 20MHz VCO and Gated: +/-3 % of reading to 2.000 MHz; +/-5 % of reading to 20 MHz		
Jitter:	<0.1 % 50 pS		
<b>WAVEFORM CHARACTERISTICS</b>			
Sinewave Total harmonic distortion:	<1 % from 2 mHz to 20.0 Hz <.5 % from 20 Hz to 100 KHz <1 % from 100 KHz to 1 MHz		
Harmonic signals:	>25 db below the carrier level from 1 MHz to 20 MHz		
Triangle Linearity:	Better than 99% up to 100 KHz (measured between 10% to 90% of amplitude)		
Squarewave, Pulse:	Rise/Fall time: <12 nS (10 % to 90 % of amplitude) Abberation: <5 %		
TTL Pulse:	Rise/Fall time: <25 nS		
<b>OUTPUT CHARACTERISTICS</b>			
Stand-by mode:	Output Normal or Disabled, selectable		
Impedance:	50 ohms +/-2 %		
Output Level:	20.0 mV to 30.0 V p-p into open circuit; 10.0 mV to 15.0 V p-p into 50 ohms		
Resolution:	2 1/2 digits (150 counts) with exponent		
Accuracy (1 KHz):	+/-2 % of reading from 1.0 V to 15.0 V +/-3 % of reading from .10 V to 1.50 V +/-4 % of reading from 10 mV to 150 mV		
Vernier Control:	Continuous throughout the output level		
Output Protection:	protected against continuous short to case ground.		
Flatness (sine):	<0.5 db to 1 MHz; <1.5 db to 20 MHz		
Offset Resolution:	3 digits with exponent		
Offset Range:	Offset and amplitude are independently selectable within the following window levels:		
<b>Window</b>	<b>Amplitude Level</b>	<b>Offset Range</b>	<b>Offset Accuracy</b>
+/-7.50 V	1.0E 0 -15.0E 0	0E 0 - 7.00 E 0	1% +/--(1% of Ampl + 40mV)
+/-2.37 V	48E 0 - 150E 0	0E 0 - 2.13 E 0	2% +/--(1% of Ampl + 10mV)
+/-750mV	.10E 0 - .47E 0	0E-3 - 700 E-3	2% +/--(1% of Ampl + 4mV)
+/-237mV	10E-3 - 150E-3	0E-3 - 232 E-3	3% +/--(1% of Ampl + 1mV)



Table 1-1. Model 8020 Specifications (continued)

**DC CHARACTERISTICS** (models 8020 & 8022)

Range:	Variable from -15 V to +15V into open circuit; -7.5 V to +7.5 V into 50 ohms
Resolution:	3 digits (750 counts max) with exponent
Accuracy:	+/(1% of reading +20 mV) to 7.50 V; +/(2% of reading +2 mV) to 750 mV

**TRIGGERING CHARACTERISTICS**

Source:	Manual front panel push button, external TRIG IN or internal trigger generator
Modes:	
Normal:	Continuous waveform is generated
External Trigger:	Each input cycle generates a single output cycle
Internal Trigger:	An internal timer repeatedly generates a single output cycle
Gated:	External signal enables generator. First output cycle synchronous with active slope of triggering signal. Last cycle of output waveform always fully completed
External Rate:	To 20 MHz
Ext. Trigger Level:	TTL
Int. Trigger Period:	Continuously adjustable from 10 S to 1000 S
Slope:	Positive going leading edge

**LOGARITHMIC SWEEP CHARACTERISTICS**

Modes:	Auto, Manual, Triggered and Gated sweep. Main frequency, when triggered, repeatedly changes from frequency set by the frequency start to frequency set by the sweep stop setting. Frequency will sweep up, down, or up-down depending on the relationship between the sweep start and sweep stop set-ups and the selected sweep mode
Width:	10 decades maximum
Rate per Decade:	continuously adjustable from 10 mS to 1000 S (nominal) per decade
Steps per decade:	Depends on sweep time and range. Automatically adjusted by the instrument to get the maximum steps per sweep time. Maximum steps are 200; minimum steps are 50
Sweep Output:	2 V/decade for decades; 1 V/decade for 5 decades
Marker Output:	0 V with no marker; drops to approx -5 V when marker frequency is reached. Remains -5 V from the marker frequency to the end of the sweep
Sweep Stop Resolution:	Same as frequency resolution

**LINEAR SWEEP CHARACTERISTICS**

Modes:	Same as in logarithmic sweep
Sweep Width:	3 decades maximum
Sweep Time:	continuously adjustable from 10 mS to 1000 S (nominal)
Sweep Out:	0 to 10 V +/-5%
Sweep Steps:	Depends on sweep time and range. Automatically adjusted by the instrument to get the maximum steps per sweep time. Maximum steps are 1000; minimum steps are 16

Table 1-1. Model 8020 Specifications (continued)

Marker Output: Same as logarithmic sweep  
 Sweep Stop Resolution: Same as Frequency resolution

#### **VOLTAGE CONTROLLED OSCILLATOR (VCO) CHARACTERISTICS**

Input Impedance: 10 Kohms +/-5 %  
 Sensitivity: 0 V to -10 V +/-20 % produces frequency change 1/1000 from main frequency when main frequency is set to 2000 counts  
 Bandwidth: DC to 70 KHz  
 FM Sensitivity: 0 V to 100 mV modulates to 1% deviation from center frequency

#### **PULSE / RAMP CHARACTERISTICS - MODEL 8021**

Pulse Modes: Symmetrical Pulse, Positive Pulse, Negative Pulse and Complement  
 Pulse Width Range: 25.0 nS to 9.99 S  
     Max Duty Cycle: 90 % (limited by 25 nS dead time)  
 Ramp Modes: Positive Going Ramp, Negative Going Ramp  
     Ramp Width Range: 5.00 uS to 9.99 S  
     Max Frequency: 150 KHz  
     Max Duty Cycle: 90 % (limited by 1 uS dead time)  
 Resolution: 3 digits with exponent  
 Accuracy: +/-3 % +/-4 nS 25.0 nS to 99.9 mS; +/-10 % 100 mS to 9.99 S

PWM (pulse width modulation):

Mode: External PWM  
 Input: Via front panel PWM IN BNC connector  
 Input Impedance: 10 Kohms +/-5 %  
 Sensitivity: +/-5 V produces >10 % pulse width change when instrument is set to 100 counts

#### **AM CHARACTERISTICS - MODEL 8022**

Mode: External AM  
 Input: Via front panel AM IN BNC connector  
 Input Impedance: 10 Kohms +/-5 %

Carrier:

Waveform: All available front panel waveforms  
 Level Range: Continuously adjustable from 0 % to 100 % (100 % carrier level is proportional to one half of the programmed amplitude level)  
 Resolution: 3 digits (100 counts max)  
 Distortion: <1 % at 70 % modulation (Measured with  $F_c = 1$  MHz and  $F_m = 1$  KHz)

Modulating Signal:

Bandwidth: DC to 500 KHz (DC coupled)  
 Sensitivity: 0 V to 2.5 Vp-p produces 0 % to 100 % modulations respectively when carrier is set to 100 %; 0 V to 5 Vp-p produces suppressed carrier amplitude modulation (SCAM) having an output amplitude level of 0 V to 15 Vp-p into 50 ohms respectively when carrier is set to 0 %

Table 1-1. Model 8020 Specifications (continued)

**GPIB INTERFACE (IEEE-488-1978) - Option 1**

Programmable controls:	All front panel controls except POWER switch; Output may be disabled through a bus command
Subsets:	SH1, AH1, T6, TE0, L4, LE0, SR1, RL1, PP2, DC1, DT1, C0
Data Output Format:	Fixed output format consisting of 15 or 17 ASCII characters plus terminators
Data Input Format:	ASCII characters lower or upper case. ASCII characters smaller than 20 HEX (32) are ignored except CR (0D HEX)
Service Request:	Selectable for illegal commands, illegal parameters and error
String Termination:	Selectable CR, LF, EOI or combination of all.
Address Selection:	Front panel programming. Address is stored in a non-volatile memory

**ENVIRONMENTAL**

Operating temperature:	0 deg C to 40 deg C ambient
Specified Accuracy:	+25 deg C +/- 5 deg C
Storage temperature:	-40 deg C to +70 deg C
Humidity range:	80% R.H

**GENERAL**

Display:	4 digits 7 segment LEDs 14.2mm high with automatic decimal point, exponent and polarity indicators
Power:	115/230 Vac +/- 10 %, 50 or 60 Hz, 50 VA max
Stored Settings:	30 complete sets of front panel control settings. The previous control settings and GPIB address are stored in a non-volatile memory. Storage guaranteed for 24 month
Dimensions:	87 x 210 x 390 mm (H x W x L)
Weight:	Approximately 5 Kg

## SECTION 2

# INSTALLATION

### 2-1. INTRODUCTION

This section contains information and instructions necessary for the installation and shipping of the function generators - 8020 series. Details are provided for initial inspection, power connection, grounding safety requirements, installation information, and re-packing instructions for storage or shipment.

### 2-2. UNPACKING AND INITIAL INSPECTION

Unpacking and handling of the counter requires only the normal precautions and procedures applicable to the handling of sensitive electronic equipment. The contents of all shipping containers should be checked for included accessories and certified against the packing slip to ascertain that the shipment is complete.

### 2-3. PERFORMANCE CHECKS

The instrument was carefully inspected for mechanical and electrical performance before shipment from the factory. It should be free of physical defects and in perfect electrical order upon receipt. Check the instrument for damage in transit and perform the electrical procedures outlined in Section 5. If there is indication of damage or deficiency, see the warranty in this manual and notify your local Tabor field engineering representative or the factory.

#### CAUTION

It is recommended that the operator be fully familiar with the specifications and all sections of this manual. Failure to do so may compromise the warranty and the accuracy which Tabor has engineered into your instrument.

### 2-4. POWER REQUIREMENTS

The function generator may be operated from any one of the following sources: a. 103.5 to 126.5 Volts (115 Volts

nominal) b. 207 to 253 Volts (230 Volts nominal).

The instrument operates over the power mains frequency range of 48 to 63 Hz. Always verify that the operating power mains voltage is the same as that specified on the rear panel voltage selector switch.

#### CAUTION

Failure to switch the instrument to match the operating line voltage will damage the instrument and may void the warranty.

The Model 8020 should be operated from a power source with its neutral at or near ground (earth potential). The instrument is not intended for operation from two phases of a multiphase ac system or across the legs of a single-phase, three-wire ac power system. Crest factor (ratio of peak voltage to rms) should be typically within the range of 1.3 to 1.6 at 10% of the nominal rms mains voltage.

### 2-5. GROUNDING REQUIREMENTS

To insure the safety of operating personnel, the U.S. O.S.H.A. (Occupational Safety and Health) requirement and good engineering practice mandate that the instrument panel and enclosure be "earth" grounded. All Tabor instruments are provided with an Underwriters Laboratories (U.L. and V.D.E) listed three-conductor power cable, which when plugged into an appropriate power receptacle, grounds the instrument. The long offset pin on the male end of the power cable carries the ground wire to the long pin of the Euro connector (DIN standard) receptacle on the rear panel of the instrument.

To preserve the safety protection feature when operating the instrument from a two-contact outlet, use a three-prong to two-prong adapter and connect the green lead on the adapter to an "earth" ground.

**CAUTION**

To avoid operator shock hazard do not exceed the power mains voltage frequency rating which limits the leakage current between case and power mains. Never expose the instrument to rain, excessive moisture, or condensation.

**2-6. INSTALLATION AND MOUNTING**

The instrument is fully solid state and dissipates only a small amount of power. No special cooling is required. However, the instrument should not be operated where the ambient temperature exceeds 40 deg C, when the relative humidity exceeds 80% or condensation appears anywhere on the instrument. Avoid operating the instrument close to strong magnetic fields which may be found near high power equipment such as motors, pumps, solenoids, or high power cables. Use care when rack mounting to locate the instrument away from sources of excessive heat or magnetic fields. Always leave 4 cm (1.5 inches) of ventilation space on all sides of the instrument.

**2-7. BENCH OPERATION**

The Model 8020 is shipped with plastic feet, tilt stand in place and ready for use as a bench or portable instrument. See outline drawing Figure 2-1 for dimensions.

**2-8. RACK MOUNTING**

The instrument may be rack mounted in a standard 19 inch rack. The instrument may be rack mounted in Rack Mount Kit option 8020-rack.

**2-9. PORTABLE USE**

The instrument may be used in applications requiring portability. A tilt stand consisting of two retractable legs is provided with each unit.

**2-10. SHORT TERM STORAGE**

If the instrument is to be stored for a short period of time (less than three months), place cardboard over the panel and cover the instrument with suitable protective covering such as a plastic bag or strong craft paper. Place power cable and other accessories with the instrument. Store the covered voltmeter in a clean dry area that is not subject to extreme temperature variations or conditions which may cause moisture to condense on the instrument.

**2-11. LONG TERM STORAGE OR RE-PACKAGING FOR SHIPMENT**

If the instrument is to be stored for a long period or shipped, proceed as directed below. If you have any questions contact your local Tabor field engineering representative or the Tabor Service Department at the factory.

If the original Tabor supplied packaging is to be used proceed as follows:

1. If the original wrappings, packing material, and container have been saved, re-pack the instrument and accessories originally shipped to you. If the original container is not available, one may be purchased through the Tabor Service Department at the factory.
2. Be sure the carton is well sealed with strong tape or metal straps.
3. Mark the carton with the model number and serial number with indelible marking. If it is to be shipped, show sending address and return address on two sides of the box; cover all previous shipping labels.

If the original container is not available, proceed as follows:

1. Before packing the unit, place all accessories into a plastic bag and seal the bag.
2. For extended storage or long distance shipping only, use U.S. government packing method II C and tape a two-unit bag of desiccant (per MIL-D-3464) on the rear cover.
3. Place a 13 cm (5 inch) by 30 cm (12 inch) piece of sturdy cardboard over the front panel for protection.
4. Place the counter into a plastic bag and seal the bag.
5. Wrap the bagged instrument and accessories in one inch thick flexible cellular plastic cushioning material (per PPP-C-795) and place in a barrier bag (per MIL-B-131). Extract the air from bag and heat seal.
6. Place bagged instrument and accessories into a 250 mm (10 inch) x 360 mm (14 inch) x 508 mm (20 inch) fiber board box (per PPP-B-636 type CF, class WR, variety SW, grade V3C). Fill additional spaces with rubberized hair or cellular plastic cushioning material. Close box in accordance with container specifications. Seal with sturdy water resistant tape or metal straps.
7. Mark container "DELICATE INSTRUMENT", "FRAGILE", etc. Mark instrument model and serial number and date of packaging. Affix shipping labels as required or mark according to MIL-STD-129.

**NOTE**

If the instrument is to be shipped to Tabor for calibration or repair, attach a tag to the instrument identifying the owner. Note the problem, the symptoms, and service or repair desired. Record the model and serial number of the instrument. Show the work authorization order as well as the date and method of shipment. ALWAYS OBTAIN A

RETURN AUTHORIZATION NUMBER FROM THE FACTORY BEFORE SHIPPING THE INSTRUMENT TO TABOR.

**2-12. SAFETY**

Be fully acquainted and knowledgeable with all aspects of this instruction manual before using the instrument to assure operator safety and protection against personnel shock hazard. hazard.

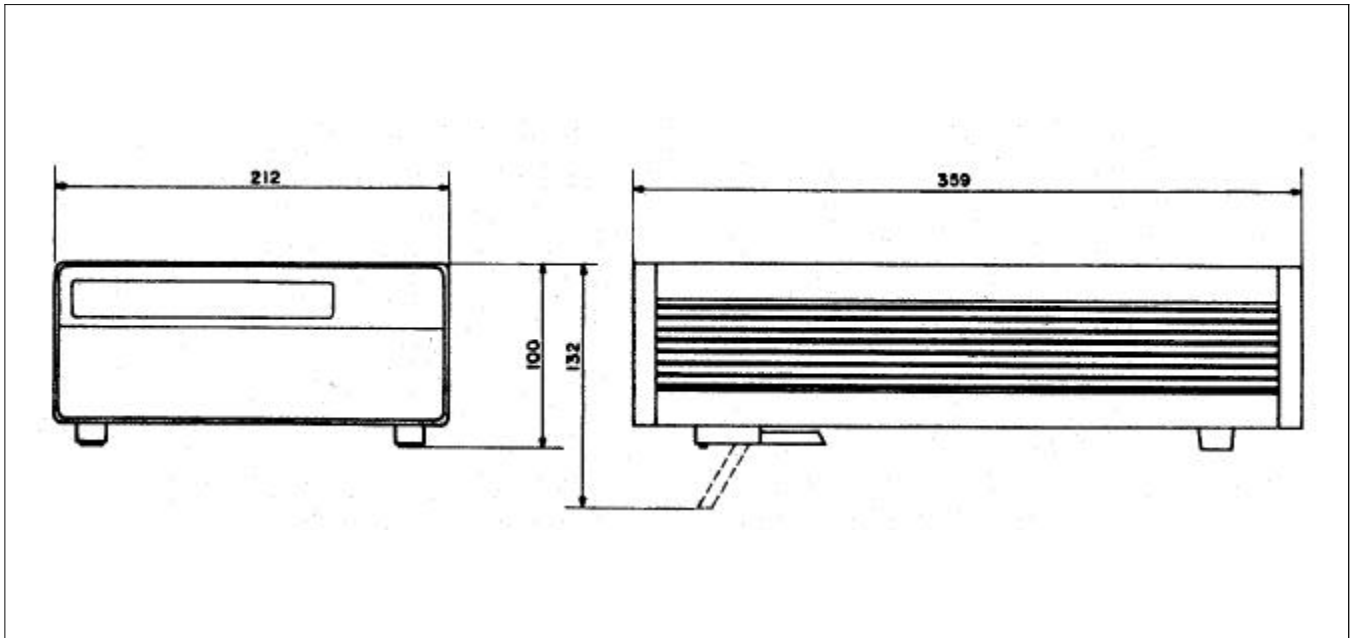

Figure 2-1. Model 8020 - outline dimensions.

This page was intentionally left blank

## SECTION 3

# OPERATING INSTRUCTIONS

### 3-1. INTRODUCTION

Model 8020 operation is divided into two general categories: basic bench operation, and IEEE-488 operation. Basic bench operation, which is covered in this section, explains how to use the model 8020 for generating the required waveform characteristics. IEEE programming (with option 1 installed) can also be used to greatly enhance the capability of the instrument in applications such as automatic test equipment. This aspect is covered in details in Section 4.

### 3-2. FRONT PANEL FAMILIARIZATION

The front panel layout of the Model 8020 is shown in Figure 3-1. The front panel is generally divided into three sections: controls, connectors, display and indicators. The following paragraphs describe the purpose of each of these items in details.

#### 3-2-1. Controls

All front panel controls except POWER are momentary contact switches. Most controls include an annunciator light for indication of the selected parameter and operating mode. Some controls do not have an annunciator light. Exercising these controls generates an immediate response on the display.

Front panel controls may be divided into functional groups: Status, Display/Modify, Trigger Mode, Operating mode, Output and Modifiers.

#### 3-2-1-1. Status

Three push-button are included in the status group. The function of each of these buttons is described in the following.

**POWER** - The POWER switch controls the AC power to the instrument. Pressing and releasing the switch once turns the power on. Pressing and releasing the switch a second time turns the power off.

**2nd/EXE** - Several push-buttons were assigned a second function which are only accessible after the [2nd] button was depressed. These functions are marked below the buttons in yellow script. Some second functions require that the [2nd] push-button be pressed again before the function is executed.

**LCL** - The LOCAL push-button when pressed, and the instrument is in its remote mode (but not in remote lock-out condition LLO), restores the instrument to its local operating mode. When the generator is in local operating mode, pressing this push-button generates no response. A 2nd function is assigned to this switch. Depressing this push-button after the [2nd] button modifies the numeric read-out to display the programmed GPIB address.

#### 3-2-1-2. Display/Modify

There are two DISPLAY/MODIFY push-buttons which are used for modifying the displayed reading. Each time a button is depressed a different parameter is displayed. The selected parameter is indicated by an LED. The dimensions which are associated with each parameter are located below the numeric display. The following parameters may be displayed and modified:

**FREQ** - Frequency of the selected output waveform. Frequency is defined for repetitive signals only. When the function generator is set to operate in triggered mode, the programmed frequency value has no effect on the output. In gated mode, the frequency defines the repetition rate within the gating signal. In sweep mode, the programmed value defines the sweep start point. The programmed frequency retains its value at both SYNC and the main output connectors.

**AMPL** - Amplitude of the selected waveform at the main output connector. The output signal is driven from a 50 ohms source therefore, the value of the amplitude parameter is specified and accurately controlled only when the output is terminated with 50 ohms. If the signal from the output connector is connected to an high impedance circuit, the actual amplitude level at the output connector



is doubled. Amplitude control has no effect on the amplitude level at the SYNC output connector.

**OFST** - DC offset of the selected waveform at the main output connector. Similarly to the amplitude, the offset parameter is specified and accurately controlled only when the output is terminated with 50 ohms. Offset control has no effect on the SYNC output connector.

**WID** - (Model 8021 only) The width parameter is common to the pulse and the ramp waveforms. When the function generator is set to operate in pulse mode, this parameter specifies the pulse width at the output connector. When the instrument is set to operate in ramp mode, this parameter specifies the ramp width at the output connector.

In pulse mode, the pulse width parameter defines the time interval between two consecutive transitions; positive to negative transition in normal output mode or negative to positive transition in pulse complement mode. The displayed and specified value is that obtained at the 50 % of amplitude setting.

The definition of ramp width is a little more complicated because the edges are less defined. In this case the specified and displayed ramp width value is that obtained by the turn point of the edges - positive to negative turning points in positive ramp output or negative to positive turning points in negative ramp output.

**CARR** - (Model 8022 only) Carrier defines the amplitude of the output waveform signal when the function generator is set to operate in its AM mode and when no

modulating signal is applied to the EXT. AM input connector. The carrier level is specified as percentage of the programmed amplitude value where 100 % carrier is equivalent to 50 % of the displayed amplitude level.

The carrier signal is driven from a 50 ohms source therefore, the value of the carrier parameter is specified and accurately controlled only when the output is terminated with 50 ohms. If the signal from the output connector is connected to an high impedance circuit, the actual carrier level at the output connector is doubled. Carrier control has no effect on the amplitude level at the SYNC output connector.

**STOP** - Defines the sweep stop frequency. When the function generator is set to operate with one of its sweep modes, the waveform at the output connector sweeps from frequency set by the **FREQ** setting to that set by the stop frequency. In several sweep modes sweep stop may change its function to sweep start. The programmed frequency retains its value at both SYNC and the main output connectors.

**TIME** - In linear sweep mode, sweep time determines the time that it takes for completing one sweep cycle. Sweep time is different for logarithmic sweep mode where the specified value is that required for sweeping one decade. The generator may be set to sweep over 10 decades. In that case, the sweep time should be multiplied by ten. Decade size ranges from 200 to 1999 counts (or 20:1 if settings other than full and minimum scales are required). If only part of the decade is being swept, the sweep time is reduced proportionally.

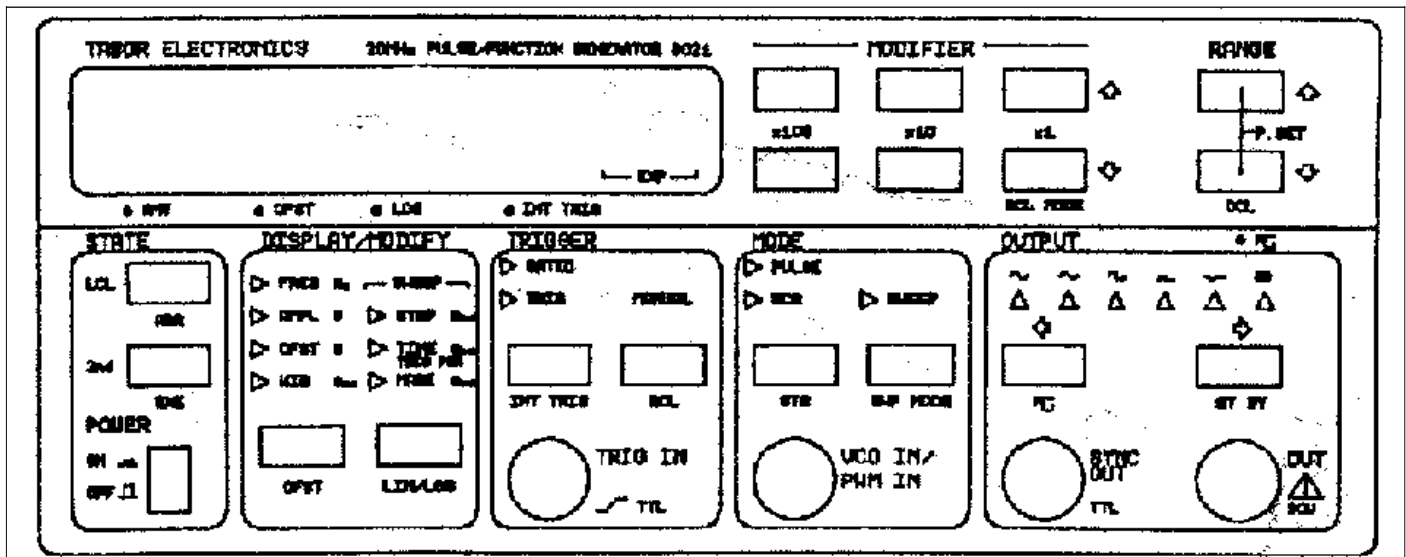

Figure 3-1. Front Panel Controls, Indicators and Connectors

**MARK** - Specifies the frequency of which the sweep marker changes its voltage level at the marker output connector. The marker output is only active when the function generator is set to operate with one of its built-in sweep modes.

**TRIG PER** - A built-in generator provides an internal triggering stimulant in such cases where an external signal is not available. The displayed value specifies the interval between consecutive triggering sequences.

Table 3-2 lists the limits for each of the above parameters.

### 3-2-1-3. Trigger Mode

Two push-buttons are grouped in the TRIGGER MODE section. Selection of one of the trigger modes is done by depressing one of these buttons. The selected mode is indicated by an LED. Model 8020 may be triggered from either one of the following sources:

1. External signal which may be applied to the TRIG IN connector
2. An internal - asynchronous trigger generator
3. GPIB commands (like GET)
4. Front panel [MANUAL] push-button

The [MANUAL] trigger is active when the instrument set to operate in its external trigger mode. This push-button when depressed serves as a replacement for an external trigger source.

### 3-2-1-4. Operating Mode

Two push-buttons are available at the operating mode group. Selection of one of the operating modes is done by depressing one of these buttons. The selected mode is indicated by an LED.

Model 8020 may operate in several operating mode such as sweep or VCO modes. Model 8021 provides two additional modes: pulse and PWM. Model 8022 provides additional amplitude modulation mode.

### 3-4-1-5. Output

There are two push-buttons in the OUTPUT group. These buttons are used for selecting an output waveforms for the output connector. The selected function is indicated by an LED.

### 3-4-1-6. Modifier

The MODIFIER push-buttons simulate digital potentiometers. The MODIFIER push-buttons operate in conjunction with the DISPLAY/MODIFY group. There are four sets of modifying buttons. Three sets are dedicated for changing the displayed read-out. One set changes the range of the displayed parameter.

### 3-2-2 Connectors

The connectors are used for connecting the Model 8020 to the unit under test and to and to external triggering source.

**1. TRIG INPUT** - The TRIG INPUT connector is used for applying an external triggering source to the function generator.

**2. VCO INPUT** - The VCO INPUT connector is used for applying an external dc voltage source to the function generator. The same input is used for connecting a pulse width modulating signal (model 8021 only) or for connecting an amplitude modulating signal (model 8022 only).

**2a. VCO/PWM INPUT** - The VCO/PWM INPUT (model 8021 only) connector serves two functions. In VCO operating mode this input is used for applying an external dc voltage source to the function generator. The same input is used for connecting a pulse width modulating signal when the instrument is set to operate in pulse mode.

**2b. VCO/AM INPUT** - The VCO/AM INPUT (model 8022 only) connector serves two functions. In VCO operating mode this input is used used for applying an external dc voltage source to the function generator. The same input is used for connecting an amplitude modulating signal when the instrument is set to operate in its AM mode.

**3. SYNC OUT** - The SYNC OUT connector outputs fixed amplitude pulses from a 50 ohms source. This output is synchronous with the main output.

**4. OUTPUT** - The OUTPUT connector is used as the main output for the function generator. Output is driven from a 50 ohms source. Special care should be taken when these outputs are connected to the device under test because these outputs are capable of delivering up to 30 Vp-p.

### 3-2-3. Display And Indicators

**1. DISPLAY** - The function of the numeric display is to indicate the value of the various parameters. The display consists of a 4 digit mantissa and a single digit exponent. The exponent uses a leading minus indicating negative values. The sign on the exponent changes to + for zero or positive values. The display is also used for indicating other information such as messages.

**2. DIMENSIONS** - Parameter dimensions are located below the numeric display. there are 3 indicators which, together with the exponent, are used for determining the correct value of the displayed parameter.

**3. INDICATORS** - 24 indicators are located on the front panel. These indicators are used as pointers to a selected parameter such as frequency, amplitude and offset or modes such as gated, triggered and VCO.

### 3-3. REAR PANEL FAMILIARIZATION

#### 3-3-1. Connectors And Switches

**1. AC RECEPTACLE** - Power is applied through the supplied power cord to the 3-terminal AC receptacle. Note that the selected ac mains voltage is marked on the line voltage selector switch.

**2. LINE SWITCH** - The LINE VOLTAGE SELECTOR switch selects one of the primary voltage which are marked on both sides of the switch.

**3. LINE FUSE** - The line fuse provides protection for the AC power line input. For information on replacing this fuse, refer to Section 5.

**4. IEEE-488 CONNECTOR** - This connector is used for connecting the instrument to the IEEE-488 bus.

**5. SWEEP OUT CONNECTOR** - This connector is used for connecting the instrument the X input on the oscilloscope. Its output is either fixed, in linear sweep mode, or proportional to the sweep time per decade, in logarithmic sweep mode.

**6. MARKER OUTPUT CONNECTOR** - This connector is used for connecting the function generator to the Z input on the oscilloscope. This output is only active when sweep mode is on.

### 3-4. POWER-UP PROCEDURE

The basic procedure of powering up the Model 8020 is described below.

**1.** Connect the female end of the power cord to the AC mains receptacle on the rear panel. Connect the other end of the power cord to a grounded AC outlet.

#### WARNING

Be sure the power line voltage agrees with the indicated value on the rear panel of the instrument. Failure to heed this warning may result in instrument damage.

The instrument is equipped with a 3-wire power cord designed to be used with grounded outlets. When the proper connections are made, the instrument chassis is connected to the power line ground. Failure to use a properly grounded outlet may result in personal shock hazard.

**2.** Turn on the mains power by pressing and releasing the POWER switch on the front panel.

**3.** The instrument will then begin operation by performing a display and indicator test which takes approximately one second. All front panel indicators will turn on and the display will appear as follows:

**8.8.8.8**

**4.** To verify that all display segments are operating, compare the instrument's display with the above during the test.

**5.** Following the display test, the instrument proceeds by displaying its model number similar to the following:

**8020**

**6.** Once the model number is displayed, the instrument performs ROM and RAM tests. Successful execution of these tests is followed by a one second read-out of the installed software revision similar to the example below:

**So 1.0**

**7.** Following the displayed software revision, the instrument proceeds with displaying the installed options. When no option is installed, the instrument skips this message. If option 1 (GPIB) is installed, the instrument displays the following message:

**OPt.1**

8. Following the option message, the instrument proceeds with displaying the previously selected GPIB primary address. If GPIB option is not installed the instrument skips this message. The GPIB address is set by front panel programming and is stored in the non-volatile memory. For example, with the generator programmed to address 15, the display will show:

**IE15**

9. Following these display messages, the instrument will commence its normal operating mode and begin generating waveforms. Note that the instrument is equipped with a non-volatile memory. This memory automatically monitors front panel traffic and retains its latest set-up for events such as accidental power loss. In case of power loss the instrument resumes operation with its previously programmed front panel set-up.

It is possible to remove the sequence of displayed messages from the power up procedure by using a built-in shift function. Depressing [SHIFT] and then [RANGE UP] in sequence writes a special code to the non-volatile memory. The next time the generator is powered up, the instrument will skip the power up procedure and will immediately commence with displaying the front panel set-up. repeating the sequence of [SHIFT] and [RANGE UP] restores normal power up procedure. Other shift functions

Table 3-1. Default States After Software Reset

are described later in this section.

**3-5. SOFTWARE RESET**

One, who is not yet fully familiar with front panel operation of the function generator, may find himself locked into a “dead-end” situation where nothing operates the way it should. The fastest way of restoring the generator to a known state is by resetting its software. This may be done by pressing the [2nd] push-button and then pressing the [DCL] push-button (second function to the [RANGE DOWN] push-button). The instrument then resets to its factory selected defaults. Table 3-1 summarizes these defaults.

**3-5-1. Parameter Preset**

As discussed in paragraph 3-5, software reset places all front panel parameters at their factory selected defaults. It may however be required to preset one or two parameters and leave the rest untouched. In that case the instrument provides additional capabilities with its [P.SET] (preset) function. Depressing simultaneously the [RANGE UP] and the [RANGE DOWN] push-buttons modifies the displayed parameter to its preselected default value. Defaults values are summarized in Table 3-1.

<b>FUNCTION</b>	<b>DESCRIPTION</b>	<b>DEFAULT STATE</b>
FREQ	Frequency	10.00 KHz
AMPL	Amplitude	1.00 V
OFST	Offset	0.00 V
WID	Pulse/Ramp Width	10.0 S
CARR	Carrier Level	100 %
STOP	Sweep Stop Frequency	2.00 KHz
TIME	Sweep Time	1.00 S
T.PER	Internal Trigger Period	1.00 S
MARK	Sweep Marker Frequency	5.00 KHz
DC AMPL	DC Amplitude	0.00 V
2nd Functions OFST	Offset Mode	Off
LIN/LOG	Sweep Mode	Linear
INT TRIG	Internal Trigger Mode	Off
SWP MODE	Sweep Mode	Sweep up
ST. BY	Stand By	Off
STATUS	IEEE Status	Local
DISPLAY/MODIFY	Displayed Parameter	Frequency
TRIGGER	Trigger Mode	Continuous
MODE	Operating Mode	Normal
OUTPUT	Output Waveform	Sinewave

**NOTE**

Software reset has no effect on stored front panel set-ups in memory locations 00 through 30. Software reset also has no effect on the programmed GPIB address.

**3-6. DISPLAY MESSAGES**

Model 8020 has several display messages pertaining to its operation. The generator also displays an error indication when a front panel programming error is detected. These messages and error indications are discussed in the following. Note that the instrument has a number of additional display messages associated with IEEE-488 programming. These messages are discussed in section 4 of this manual.

**3-7. DETECTING PROGRAMMING ERRORS**

Model 8020 is a product of many years of experience and complete understanding of human engineering requirements. During its design stage, a great deal of time was devoted for simplifying front panel programming procedures, thereby minimizing the potential of programming errors. It is impossible however for an inexperienced operator to completely avoid some errors. For such cases, the function generator employs a built-in error detection mechanism which warns against programming errors.

Errors are categorized in four main groups:

1. General errors
2. Pulse/Ramp setup errors
3. Offset errors
4. IEEE errors

**3-7-1. General Errors**

Errors in this group are caused by improper usage of the instrument. Such errors occur while attempting to place the instrument in an illegal mode. For example, depressing simultaneously two push-buttons (except [P.SET]) has no valid definition. In this case, the instrument simply ignores this error and continues with its normal operation.

**3-7-2. Pulse/Ramp Set-up Errors (model 8021 only)**

The pulse/ramp setup errors are inter-parameter inconsistencies errors, such as pulse width greater than the selected period. The pulse generator tests the programmed

parameter every time that a modifier push-button is depressed. Programming the Model 8020 with pulse/ramp errors is possible and executable however, when such errors are detected, the light next to the selected waveform starts blinking; indicating that the signal at the output connector may emerge with other parameters than those programmed. The light blinks until the error conditions are removed.

Pulse/Ramp errors may occur under one or more of the following conditions:

1. The programmed pulse/ramp WID (width) parameter is greater than the selected period (1/FREQ).
2. Model 8021 is placed in sweep mode and the programmed pulse/ramp width parameter is greater than the selected sweep stop period.
3. Model 8021 is placed in internal triggered mode and the programmed pulse/ramp width is greater than the selected internal trigger period.
4. The programmed ramp width is outside the limit of 5.00  $\mu$ S.
5. The programmed ramp frequency is outside the limit of 150 KHz.

**3-7-3. Offset Errors**

Normally, the output waveform is used symmetrically around the 0 V line. This means that with an output voltage of 10 V<sub>p-p</sub> and with no offset applied, the lowest peak reaches -5 V. Consequently, the highest peak reaches +5 V. The instrument provides an additional flexibility by using its output waveform in conjunction with an offset voltage. It is however, impossible to exceed the instrument limits. Offset and amplitude are independently selectable within the limits given in Table 3-2.

The instrument will reject any attempt to call the [OFST] function if the sum of the amplitude and the offset exceeds the specified limits and will display the following error message on its read-out:

**ERR**

The function generator then resumes normal operation. No offset is applied to the output waveform.

Tabel 3-2. Offset Amplitude Programming Limits

Window	Amplitude Range	Offset Range
+/-7.50 V	1.0E0 -15.0E0	0E0 - 7.00E0
+/-2.37 V	48E0 - 150E0	0E0 - 2.13E0
+/-750 mV	.10E0 - .47E0	0E-3 - 700E-3
+/-237 mV	10E-3 - 150E-3	0E-3 - 232E-3

**3-7-4. IEEE-488 Errors**

In general, whenever a GPIB programming attempts to put the model 8020 into an error condition, the function generator responds in two ways. First by displaying a front panel message and than, if programmed so, by raising an SRQ flag in its status byte. The controller may then address the generator using the serial poll command and request its status byte.

The generator incorporates a number of display messages which are associated with errors involving GPIB interface programming. These messages are discussed in detail in Section 4 of this manual.

There is one message however, which should be explained at this point because it may interfere with front panel operation. A remote enable or a device dependent command sent to the instrument through the bus turns the REMOTE light on. In this case, all front panel push-buttons except [LCL] are disabled. Press one of these push-buttons causes the function generator to respond with the following message:

**LcL**

This message indicates that the instrument expects that the [LCL] push-button be first depressed otherwise front panel operation is ignored. After the [LCL] button is depressed, the REMOTE light turns off and the instrument is ready to accept further front panel programming sequences.

Unless the [LCL] push-button is pressed and the REMOTE light turns off.

**3-8. SELECTING 2nd FUNCTIONS**

A few front panel push-buttons were assigned a secondary function. These functions are printed in yellow below the button and are accessible through the [2nd] push-button.

There are twelve front panel buttons which were assigned a secondary function. These functions are:

- |                 |                   |
|-----------------|-------------------|
| <b>ADR</b>      | <b>STO</b>        |
| <b>EXE</b>      | <b>SWP MODE</b>   |
| <b>OFST</b>     | <b>COMPLEMENT</b> |
| <b>LIN/LOG</b>  | <b>ST-BY</b>      |
| <b>INT TRIG</b> | <b>RCL MODE</b>   |
| <b>RCL</b>      | <b>DCL</b>        |

The operation of these secondary functions is described later in this chapter. Pressing the [2nd] push-button generates the following display read-out:

**2nd ?**

The question mark (?) appears blinking; indicating that the instrument is ready for a consequent press of another push-button which was assigned a secondary function. Depressing [2nd] once more cancels this function.

**3-9. MODIFYING PARAMETERS**

There are various parameters, such as frequency and amplitude, which control the shape of the waveform at the output connector. Modification of a specific parameter is simply done by pressing the push-button below the requested parameter until the light next to the required parameter illuminates. At this time the numeric readout displayed a value plus an exponent. The dimension is marked on the panel next to each parameter. For exam-

ple, the FREQ dimension is Hz. Display readout of 10.00 (exp)+3 tells us that the output waveform is programmed to have a frequency of 10.00 KHz. Limits for each parameter are given in Table 3-3. The parameter is then modified using the [MODIFIER] and the [RANGE] push-buttons.

The parameters which can be modified are marked on the front panel as follows:

<b>FREQ</b>	<b>STOP</b>
<b>AMPL</b>	<b>WID (model 8021)</b>
<b>TIME</b>	<b>CARR (model 8022)</b>
<b>OFST</b>	<b>MARK</b>

In addition, some parameters are accessible through the [2nd] button. These parameters are:

<b>ADR</b>	<b>SWP MODE</b>
<b>RCL</b>	<b>RCL MODE</b>
<b>STO</b>	

**3-9-1. Modifier**

The modifier group consists of three sets of push-buttons each set having its top button marked with an arrow pointing up and its bottom key marked with an arrow pointing down. These modifier push-button control the displayed readout within a selected range.

[x1 UP] or [x1 DOWN] push-buttons when depressed and released once increments or decrements the least sig-

nificant digit on the numeric display. Depressing these buttons for more than one second modifies this digit constantly until the button is released or until the parameter limit is encountered. Incrementing the [x1] above 9 carries 1 to the second digit.

The [x10 UP] or [x10 DOWN] push-buttons control the second digit. Their operation is similar to the [x1] operation. Incrementing the [x10] above 9 carries 1 to the second digit.

The [x100 UP] or [x100 DOWN] push-buttons control the third and the most significant digit.

**3-9-2. RANGE**

The [RANGE] buttons control the range of the displayed parameter. Depressing and releasing the [RANGE UP] or the [RANGE DOWN] buttons increases or decreases respectively the displayed range. Depressing these buttons when the generator is already at its highest or lowest range will produce no further change.

**3-9-3. Parameter Limits**

In general, parameters were assigned definite boundaries. The instrument was design in such a way that front panel programming, under no circumstances, may lead to an error situation by exceeding the specified limits. GPIB parameter programming errors are discussed in section 4. Front panel programming permits modification of parameters within the limits which are given in

Table 3-3. Front Panel Parameter Entry Limits

PARAMETER	LOW LIMIT	HIGH LIMIT	REMARKS
FREQ (frequency)	2.00 mHz	20.00 MHz	
AMPL (amplitude)	10 mV	15.0 V	Into 50 ohms
AMPL (dc amplitude)	0 mV	+/-7.50 V	DC output waveform
OFST (offset)	0 mV	+/-7.00 V	Amplitude dependent
WID (pulse/ramp width)	25.0 nS	9.99 S	Model 8021 only
CARR (carrier)	0 %	100 %	Model 8022 only
STOP (log sweep stop)	2.00 mHz	20.00 MHz	
STOP (lin sweep stop)	2 counts	2000 counts	Same range
TIME (sweep time)	10 mS	1000 S	
T.PER (trigger period)	10 uS	1000 S	
MARK (log marker freq)	2.00 mHz	20.00 MHz	
MARK (lin marker freq)	2 counts	2000 counts	Same range
STORE (store)	00 #	30 #	
RECALL (recall)	00 #	30 #	
GP ADR (GPIB address)	00 #	31 #	

Table 3-3. Note that the modifier buttons [x1], [x10] and [x100] can only modify a parameter within one range. These buttons in conjunction with the [RANGE] push-button may cover the entire specified range.

### 3-10. SELECTING AN OUTPUT WAVEFORM

Selecting one of the available output waveforms is done by depressing one of the two push-buttons in the OUTPUT section until the light next to the required waveform illuminates. Models 8020 and 8022 each output six different waveshapes through the OUTPUT connector. These waveforms are:

<b>SINE WAVE</b>	<b>POSITIVE SQUARE WAVE</b>
<b>TRIANGLE</b>	<b>NEGATIVE SQUARE WAVE</b>
<b>DC</b>	<b>SQUARE WAVE</b>

Model 8021 offers eight additional waveforms DC waveform is omitted:

**PULSE**  
**PULSE COMPLEMENT**  
**POSITIVE PULSE**  
**POSITIVE PULSE COMPLEMENT**  
**NEGATIVE PULSE**  
**NEGATIVE PULSE COMPLEMENT**  
**RAMP**  
**INVERTED RAMP**

### 3-11. DISABLING THE OUTPUT

The Model 8020 features a stand-by mode which disconnects the waveform from the output connectors. The stand-by function is especially useful in places where the output is constantly connected to the device under test and where modification of waveform parameters may endanger this device.

To place the instrument in its stand-by mode depress in sequence the [2nd] and the [STBY] push-buttons. The selected waveform light turns off; indicating that the output signal is disconnected from the connectors.

To resume normal operation simply depress one of the push-button in the OUTPUT section. The light next to the previously selected waveform illuminates; indicating that the output signal is now connected to the output connectors.

### 3-12. SELECTING AN OPERATING MODE

Model 8020 may operate as a function generator, as a sweep generator and as a voltage controlled oscillator. Selecting one of these operating modes is done by pressing one of the push-buttons in the MODE section until the light next to the desired mode illuminates.

In addition, Model 8021 offers pulse operating mode. Model 8022 offers AM mode. When all lights in the mode section are off, the generator is placed in its normal function generator mode.

#### 3-12-1. Function Generator Mode

Function generator mode is the normal operating conditions where the output waveform is programmed to have various parameters. These parameters are stable throughout the continuous operation of the generator. The generator is placed in its normal operating mode when all light in the MODE section are off.

#### 3-12-2. Sweep Generator Mode

Placing the model 8020 in sweep mode transforms this instrument into an independent sweep generator. The function generator has eight built-in sweep modes of which four of them are linear sweep modes and four are logarithmic sweep modes. Selecting between linear or logarithmic sweep mode is performed as follows:

1. Depress the [2nd] push-button and observe that the display is modified to indicate the following:

**2nd ?**  
**(? appears flashing)**

2. Depress the [LIN/LOG] push-button in the DISPLAY/MODIFY group and observe that the LOG light below the numeric display illuminates; indicating that the generator is set to sweep having a logarithmic scale.

3. Repeating the sequence of depressing [2nd] and [LIN/LOG] push-buttons turns the LOG light off. The instrument then sweeps linearly.

#### 3-12-2-1. Selecting Sweep Direction

When placed in sweep mode, the selected waveform at the output connector repeatedly changes its frequency in a direction set by the sweep start (FREQ) parameter to frequency set by the sweep stop (STOP) parameter. The time for completing one sweep cycle is determined by the sweep time (TIME) parameter. There are four different directions that the output waveform may sweep to. The difference between the various modes is more significant when using the triggered sweep mode as described in the following:



**SWEEP UP** - The function generator, when triggered, sweeps from value set by **FREQ** to value set by **STOP**. Sweep time is determined by **TIME**. At the end of the sweep, the output waveform remains at the stop frequency. Following another trigger, the output jumps quickly to its start frequency and the above cycle is repeated. In normal mode the generator repeats its sweep cycle continuously.

**SWEEP DN** - The sweep down mode is similar to the sweep up mode except that the output waveform, when triggered, sweeps from frequency set by the sweep stop (**STOP**) parameter to frequency set by the sweep start (**FREQ**) parameter. Sweep time is determined by the **TIME** parameter. At the end of the sweep, the output waveform remains at the start frequency. Following another trigger, the output jumps quickly to its stop frequency and the above cycle is repeated. In normal mode the generator repeats its sweep cycle continuously.

**SWEEP UP-DN** - The function generator, when triggered, sweeps from value set by the **FREQ** parameter to value set by the **STOP** parameter and back to the **FREQ** value. Sweep time is doubled than the displayed **TIME** parameter. At the end of the sweep, the output waveform remains at the start frequency. Following another trigger, the above cycle is repeated. In normal mode the generator repeats its sweep cycle continuously.

**SWEEP DN-UP** - The sweep down mode is similar to the sweep up mode except that the output waveform, when triggered, sweeps from value set by the **STOP** parameter to value set by the **FREQ** parameter and back to the **STOP** value. Sweep time is doubled than the displayed **TIME** parameter. At the end of the sweep, the output waveform remains at the stop frequency. Following another trigger, the above cycle is repeated. In normal mode the generator repeats its sweep cycle continuously.

Selecting one of the above sweep directions is described in the following. The same procedure is used for both linear and logarithmic sweep scales.

1. Depress the [2nd] push-button and observe that the display is modified to indicate the following:

**2nd ?**  
(? appears flashing)

2. Depress the [SWP MODE] push-button in the **MODE** group and observe that one of the following read-outs is displayed:

**UP, dn, U-d or d-U**

This reading indicates the selected sweep mode. To modify the selected sweep mode to one of the above modes depress the [x1 UP] modifier push-button until the selected mode is displayed.

3. Depress the [EXE] push-button. The output waveform now sweeps with the selected sweep mode.

### 3-12-3. Voltage Controlled Oscillator Mode

Placing the function generator in **VCO** (voltage controlled oscillator) operating mode removes the frequency control from its output connector. The frequency of the selected waveform is then proportional to an amplitude level of a signal which may be applied to the **VCO IN** connector. **VCO** mode may also be used as **FM** (frequency modulation) mode. In this case, an applied sine-wave at the **VCO IN** connector determine modulation characteristics.

The generator is placed in **VCO** operating mode when the light next to **VCO** illuminates.

### 3-12-4. Pulse Generator Mode (model 8021 only)

Model 8021 offers additional capability to the basic function generator by allowing modification of its output duty cycle (**WID**). Ramp and Square waveforms at the output connector remains symmetrical (50 % duty Cycle) in normal operating mode. Placing the generator in **PULSE** mode replaces output symmetry to that programmed for **WID**. Width to frequency relation should be observed. When error conditions exists the light next to the selected waveform blinks.

**PULSE** mode may also be used as **PWM** (pulse width modulation) mode. In this case, an applied sinewave at the **PWM IN** connector determine modulation characteristics. Model 8021 is placed in **PULSE** operating mode when the light next to **PULSE** illuminates.

### 3-12-5. AMMode (model 8022 only)

Model 8022 offers additional capability to the basic function generator by allowing amplitude modulation (AM) of its output waveform (carrier). Placing the function generator in AM mode modifies output amplitude to that obtained by the amplitude-carrier (AMPL-CARR) relationship. Modulating signal is applied to the AM IN connector. Operator may select any of the available output waveforms as carrier. Frequency and amplitude limits of the modulating signal should be observed.

The Model 8022 is placed in AM operating mode when the light next to AM illuminates.

### 3-13. TRIGGERING THE PULSE GENERATOR

Selecting one of the available triggering modes is simply a matter of depressing push-buttons in the TRIGGER section until the light next to the desired mode illuminates. When no light in the TRIGGER MODE section is on, the function generator operates in its normal continuous mode.

The instrument may operate in one of the following triggering modes:

**GATED** - An external signal enables the generator. First output pulse is synchronous with the active slope. Last pulse is always completed.

**TRIGGERED** - Each input cycle, at the TRIG INPUT connector, generates a single output pulse. Output pulse is synchronous with the active slope.

The Model 8020, when set to a trigger mode, accepts various stimulants. When operating from an external source, the generator may be programmed to be triggered on a leading edge of a TTL level signal.

When external source is not available, the operator has a choice of either using the MANUAL push-button or the internal trigger generator. The MANUAL button simulates an external signal. If the generator is placed in GATED mode, an output signal will be available as long as the MANUAL push-button is depressed. When the generator is set to TRIG (triggered) mode, each time the MANUAL button is depressed a single output waveform is generated. The MANUAL push-button has no effect in normal mode of operation or when the instrument is set to internal trigger mode.

To use the internal trigger generator first set the required trigger period. Place the generator in TRIG mode and depress in sequence the [2nd] and the [INT TRIG] push-button in the TRIGGER group. The INT TRIG light under the numeric display illuminates; indicating that the generator is placed in internal trigger mode. Repeating the sequence of depressing [2nd] and [INT TRIG] turns off the INT TRIG light and places the instrument in normal trigger mode.

### 3-14. USING FRONT PANEL SET-UPS

Setting-up all parameters in a versatile instrument such as the Model 8020 takes some time. The set-up time is longer when a couple of tests are involve and more than one set-up is required. The function generator incorporates a battery backed-up non-volatile memory that preserves stored information for a long time. The size of the non-volatile memory permits storage of up to 30 complete front panel set-ups. Front panel set-ups can be recalled one at a time. The generator also employs a special recall mode which permits automatic scrolling through the stored set-ups. Operator may select scrolling in an ascending or descending order.

#### 3-14-1. Store Set-ups

First modify the front panel parameters as necessary to perform your tasks. Parameter modification procedure is discussed in paragraph 3-8. When all parameters are set and checked, proceed with storing this set-up as follows:

1. Depress in sequence the [2nd] and [STO] push-button and observe that the display is modified to indicate the following:

**S xx**

“S” means that the instrument is placed in store mode. “xx” indicates the number of the present storage cell. Numbers may range from 00 to 30. Depressing [2nd] removes the generator from store set-up mode and leaves front panel settings unchanged.

2. To program individual memory cells to specific front panel set-ups depress the MODIFIER [x1 UP] or [x1 DOWN] until the desired number is displayed. Depressing [EXE] locks-in the entire front panel set-up for later usage. The instrument then resumes normal its operation.

3. Repeat the above procedure for as many set-ups that are required. Stored front panel set-ups are limited to 30.

**3-14-2. Recall Set-ups****C 00**

The model 8600 employs a non-volatile memory (RAM). The computer circuit continuously monitors front panel traffic and saves it in a special location within the RAM. This location is separate to the stored front panel set-ups. After turning AC MAINS off or in case of an accidental power failure, the generator will update front panel indicators with the last set-up before power shut-down.

To recall a front panel set-up proceed as follows:

1. Depress in sequence the [2nd] and [RCL] push-button and observe that the display is modified to indicate the following:

**C xx**

“C” means that the instrument is placed in recall mode. “xx” indicates the number of the present storage cell. Numbers may range from 00 to 30. Depressing [2nd] removes the generator from recall set-up mode and leaves front panel settings unchanged.

2. Recalling a specific front panel set-up is done by depressing the MODIFIER [x1 UP] or [x1 DOWN] until the desired cell number is displayed. Depressing [EXE] updates front panel set-up with those parameters stored in the recalled memory cell.

3. Repeat the above procedure for as many set-ups that are required. Recalled front panel set-ups are limited to 30.

**3-14-2-1. Using The Recall Mode**

Model 8020 employs a special recall mode which permits ascending or descending scrolling through a number of set-ups by pressing either the MODIFIER [x1 UP] or [x1 DOWN] push-buttons respectively. This mode is especially useful for repetitive procedures such as calibration and performance tests.

To set the function generator for operation in the recall mode proceed as follows:

1. Depress the [2nd] push-button and observe that the display is modified to indicate the following:

**2nd ?  
? appears flashing**

2. Depress the [RCL MODE] push-button (second function to [x1]) and observe that the display is modified to indicate the following:

The instrument is now set to operate in its recall mode. The display is first updated with the parameters which were stored in memory cell 00.

3. Use the MODIFIER [x1 UP] or [x1 DOWN] for scrolling through the memory bank.

4. Depress [EXE] to exit this function and to return to normal display operation.

**3-15. USING THE OFFSET**

When setting the offset parameter, the user must keep in mind that the offset is attenuated with the signal. The function generator utilizes 3 post amplitude attenuators of which 2 attenuate the signal by 20dB and one attenuates by 10dB. There is also a 10dB pre-amplifier attenuator. Ranges are internal to the instrument and are automatically selected with the required amplitude level. This may cause some confusion since the operator has no access to selecting an attenuator. Also, not knowing this fact may cause an offset error at amplitude values that seem to be reasonable. As stated before, offset is amplitude dependent. It is therefore suggested to first set up the amplitude and offset parameters independently and only then to place the generator in offset mode. Offset and amplitude are independently selectable within the limits given in Table 3-2.

To place the function generator in an offset mode, depress the [2nd] push-button and then the [OFST] push-button. If the selected offset-amplitude parameters are within the specified windows, the OFST light illuminates; indicating that the offset mode is now active. Repeating the sequence of depressing [2nd] and [OFST] turns the light off and places the instrument in its normal mode of operation. The selected waveforms will then be symmetrical.

**3-16. CHANGING THE GPIB ADDRESS**

GPIB address is modified using front panel programming therefore, conventional address switches are not provided. The non-volatile memory stores the GPIB address. Detailed instructions how to change the GPIB address are given in Section 4.

## SECTION 4

### GPIB OPERATION

#### 4-1. INTRODUCTION

The GPIB (general purpose interface bus) is an instrumentation data bus with standards originally adopted by the IEEE (Institute of Electrical and Electronic Engineering) in 1975 and given the IEEE-488 designation. In November 1987 the IEEE-488 document was revised, primarily for editorial classification and addendum, and the new document was identified as IEEE-488-1978.

This document has been the standard for general-purpose instrumentation bus (GPIB) which has been adopted by worldwide instrumentation manufacturers. In June 1987 the IEEE approved a new standard for programmable instruments and devices IEEE Standard 488.2-1987 Codes, Formats, Protocols, and Common Commands. The original document, IEEE-488-1978, was re-titled IEEE-488.1.

The IEEE-488.2 standard was designed to make the interface system easier to use by requiring that all devices provide certain capabilities such as talk and listen, respond to device clear commands, and be capable of service requests. Other functions such as parallel poll are left optional with the instrument manufacturer. The Model 8020 complies with all of the mandatory IEEE-488.1 and IEEE-488.2 requirements. Some of the issues which IEEE-488.2 Addresses are:

1. A required minimum set of IEEE-488.1 capabilities.
2. Reliable transfer of messages between a talker and listener and precise syntax in those messages.
3. A set of commands which would be useful in all instruments.
4. Common serial poll status reporting.
5. Synchronization programming with instrument functions.

This section contains general bus information as well as detailed programming information and is divided as follows:

1. General introductory information pertaining to the IEEE-488 bus may be found primarily in paragraphs 4-2 through 4-5.

2. Information necessary to connect the Model 8020 to the bus and to change the bus address is contained in paragraphs 4-6 and 4-7.

3. Programming of the instrument with general bus command is covered in paragraph 4-8.

4. Device-dependent command programming is described in detail in paragraph 4-10. The commands outlined in this section can be considered to be the most important since they control virtually all instrument functions.

5. Additional information pertaining to device status reporting and error messages can be found in paragraphs 4-13 and 4-15.

#### 4-2. BUS DESCRIPTION

The IEEE-488 bus was designed as a parallel data transfer medium to optimize data transfer without using an excessive number of bus lines. In keeping with this goal, the bus has only eight data lines which are used for both data and most commands. Five bus management lines and three handshake lines round out the complement of signal lines. Since the bus is of parallel design, all devices connected to the bus have the same information available simultaneously. Exactly what is done with the information by each device depends on many factors, including device capabilities.

A typical bus configuration for remote controlled operation is shown in Figure 4-1. The typical system will have one controller and one or more instruments to which commands are given and from which data is received. There are three categories that describe device operation. These include: controller; talker; listener.

The controller controls other devices on the bus. A talker sends data, while a listener receives data. An instrument, may be a talker only, a listener only, or both a talker and listener.

Figure 4-1. IEEE Bus Configuration

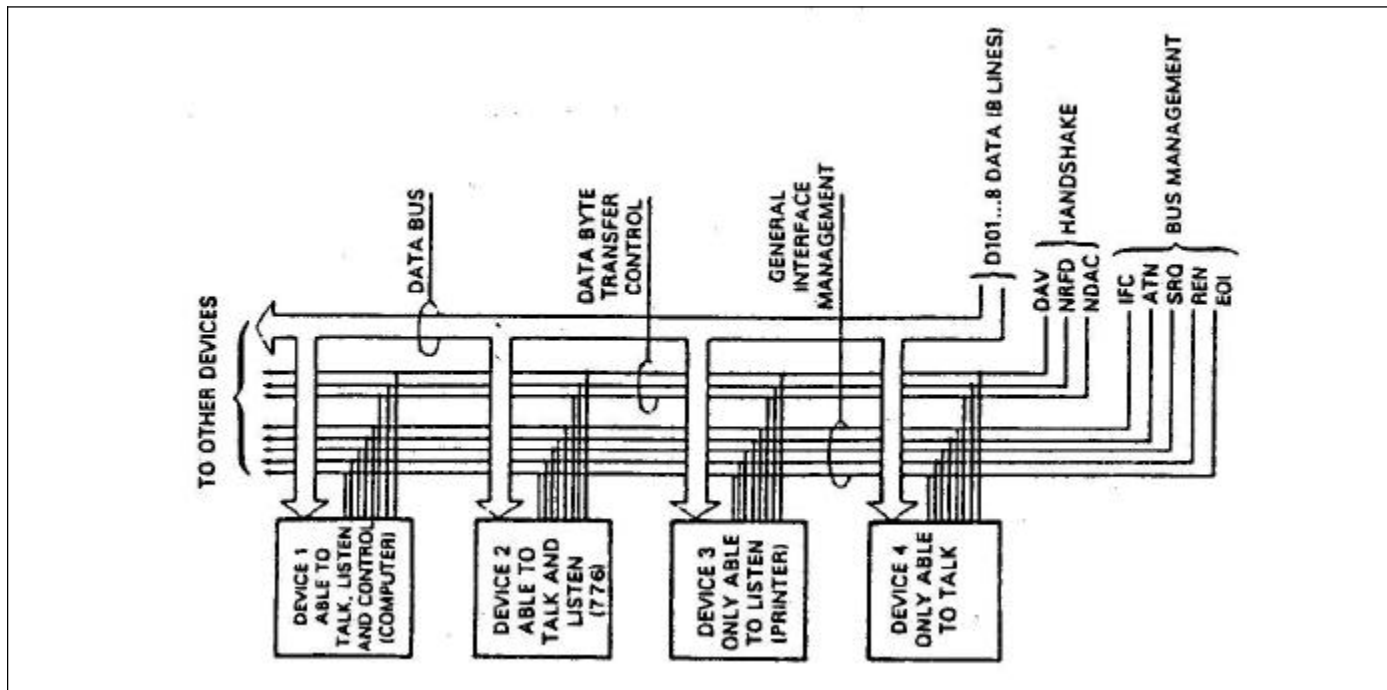

Any given system can have only one controller (control may be passed to an appropriate device through a special command). Any number of talkers or listeners may be present up to the hardware constraints of the bus. The bus is limited to 15 devices, but this number may be reduced if higher than normal data transfer rates are required or if long interconnect cables are used.

Several devices may be commanded to listen at once, but only one device may be a talker at any given time. Otherwise, communications would be scrambled much like an individual is trying to select a single conversation out of a large crowd.

Before a device can talk or listen, it must be appropriately addressed. Devices are selected on the basis of their primary address. The addressed device is sent a talk or listen command derived from its primary address. Normally, each device on the bus has a unique primary address so that each may be addressed individually. The bus also has another addressing mode called secondary addressing, but not all devices use this addressing mode.

Once the device is addressed to talk or listen, appropriate bus transactions may be initiated. For example, if an instrument is addressed to talk, it will usually place its data on the bus one byte at a

time. The listening device will then read this information, and the appropriate software is then be used to channel the information to the desired location.

#### 4-3. IEEE-488 BUS LINES

The signal lines on the IEEE-488 bus are grouped into three general categories. The data lines handle bus information, while the handshake and bus management lines assure that proper data transfer and bus operation takes place. Each of the bus lines is "active low" so that approximately zero volts is a logic "one". The following paragraphs describe the purpose of these lines, which are shown in Figure 4-1.

##### 4-3-1. Bus Management Lines

The bus management group is made up of five signal lines that provide orderly transfer of data. These lines are used to send the uniline commands described in paragraph 4-8-1.

1. **ATN** (Attention) - the ATN line is one of the more important management lines. The state of the ATN line determines whether controller information on the data bus is to be considered data or a multiline command as described in paragraph 4-8-2.

Figure 4-2. IEEE Handshake Sequence

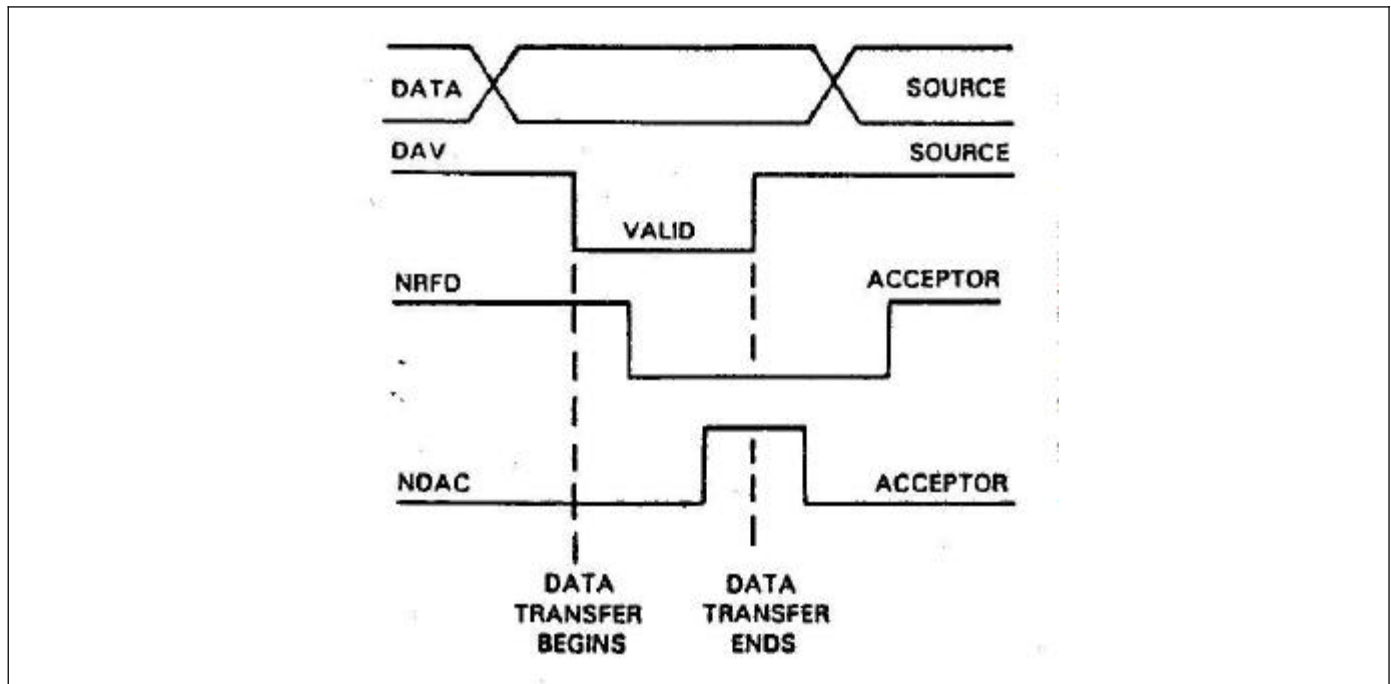

2. **IFC** (Interface Clear) - Setting the IFC line true (low) causes the bus to go to a known state.

3. **REN** (Remote Enable) - Setting the REM line low sends the REM command. This sets up instruments on the bus for remote operation.

4. **EOI** (End Or Identify) - The EOI line is used to send the EOI command that usually terminates a multi-byte transfer sequence.

5. **SRQ** (Service Request) - the SRQ line is set low by a device when it requires service from the controller.

#### 4-3-2. Handshake Lines

The bus uses three handshake lines that operate in an interlocked sequence. This method assures reliable data transfer regardless of the transfer rate. Generally, data transfer will occur at a rate determined by the slowest active device on the bus.

One of the handshake lines is controlled by the data source, while the remaining two lines are controlled by accepting devices. The three bus handshake lines are:

1. **DAV** (Data Valid) - The source controls the state of the DAV line.

2. **NRFD** (Not Ready For Data) - the acceptor controls the state of the NRFD line.

3. **NDAC** (Not Data Accepted) - the acceptor also controls the NDAC line.

The complete handshake sequence for one data byte is shown in Figure 4-2. Once data is on the bus, the source checks to see that NRFD is high, indicating that all devices on the bus are ready for data. At the same time NDAC should be low from the previous byte transfer. If these conditions are not met, the source must then wait until the NRFD and NDAC lines have the correct status. If the source is controller, NRFD and NDAC must remain stable for at least 100 ns after ATN is set low. Because of the possibility of bus hang up, some controllers have time-out routines to display error messages if the handshake sequence stops for any reason.

Once the NRFD and NDAC lines are properly set, the source sets the DAV line low, indicating that data on the bus is now valid. the NRFD line then goes low; the NDAC line goes high once all devices on the bus have accepted the data. Each device will release the NDAC line at its own rate, but the NDAC line will not go high until the slowest device has accepted the data byte.

After the NDAC line goes high, the source then sets the DAV line high to indicate that the data on the bus is no longer valid. At this point, the NDAC

line returns to its low state. Finally, the NRFD line is released by each of the devices at their own rates, until the NRFD line finally goes high when the slowest device is ready, and the bus is set to repeat the sequence with the next data byte.

The sequence just described is used to transfer both data and multiline command. The state of the ATN line determines whether the data bus contains data or commands.

#### 4-3-3. Data Lines

The IEEE-488.2 bus uses the eight data lines that allow data to be transmitted and received in a bit-parallel, byte-serial manner. These eight lines use the convention DI01 through DI08 instead of the more common D0 through D7 binary terminology. The data lines are bi-directional and, as with the remaining bus signal lines, low is true.

#### 4-4. INTERFACE FUNCTION CODES

The interface function codes are part of the IEEE-488.2 standards. These codes define an instrument's ability to support various interface functions and should not be confused with programming commands found elsewhere in this manual.

Table 4-1 lists the codes for the Model 8020. The numeric value following each one or two letter code define Model 8020 capability as follows:

**SH** - (Source Handshake Function) - The ability for the Model 8020 to initiate the transfer of message/data on the data bus provided by the SH function.

**AH** - (Acceptor Handshake Function) - The ability for the Model 8020 to guarantee proper reception of message/data on the data bus provided by the AH function.

**T** - (Talker Function) - The ability of the Model 8020 to send device-dependent data over the bus (to another device) is provided by the T function. Model 8020 talker capabilities exist only after the instrument has been addressed to talk.

**L** - (Listen Function) - The ability of the Model 8020 to receive device-dependent data over the bus (from another device) is provided by the L function. Listener function capability of the Model 8020 exist only after it has been addressed to listen.

**RS** - (Service Request Function) - The ability of the Model 8020 to request service from the controller is provided by the RS function.

Table 4-1. Model 8020 Interface Function Codes

CODE	INTERFACE FUNCTION
SH1	Source Handshake Function
AH1	Acceptor Handshake Capabilities
T6	Talker (basic talker, serial unaddressed to talk on LAG)
poll, L4	Listener (basic listener, unaddressed to listen on TAG)
SR1	Service request capability
RL1	Remote/Local capability
PP2	Parallel Poll capability
DC1	Device Clear capability
DT1	Device Trigger capability
C0	No controller capability
E1	Open collector bus drivers
TE0	No Extended Talker capabilities
LE0	No Extended Listener capabilities

**RL** - (Remote-Local Function) - The ability of the Model 8020 to be placed in remote or local modes is provided by the RL function.

**PP** - (parallel Poll Function) - The ability of the Model 8020 to respond to a parallel poll request from the controller is provided by the PP function.

**DC** - (Device Clear Function) - The ability for the Model 8020 to be cleared (initialized) is provided by the DC function.

**DT** - (Device Trigger Function) - The ability of the Model 8020 to have its output triggered is provided by the DT function.

**C** - (controller Function) - The Model 8020 does not have a controller function.

**TE** - (Extended Talker Capabilities) - The Model 8020 does not have extended talker capabilities.

**LE** - (Extended Listener Function) - The Model 8020 does not have extended listener function.

#### 4-5. SOFTWARE CONSIDERATIONS

The most sophisticated computer in the world would be useless without the necessary software. This basic requirement is also true of the IEEE-488.2 bus, which requires the use of handler routines as described in this paragraph. Before a controller can be used with the IEEE-488.2 interface, the user must make certain that appropriate handler software is present within the controller. With the IBM PC computer, for example, the GPIB interface card must be used with an additional software which contains the necessary handler software.

Other small computers that can be used as controllers have limited IEEE command capability. The capabilities of some computers depends on the particular interface being used. Often, little software “tricks” are required to achieve the desired results.

From the preceding discussion, the message is clear: make sure the proper software is being used with the instrument. Often, the user may incorrectly suspect that a hardware problem is causing fault, when it was the software that was causing the problem all along.

**4-6. HARDWARE CONSIDERATIONS**

Before the instrument can be used with the IEEE-488 bus, it must be connected to the bus with a suitable connector. Also, the primary address must be properly programmed as described in this section.

**4-6-1. Typical Controlled Systems**

The IEEE-488.2 bus is a parallel interface system. As a result, adding more devices is simply a matter of using more cables to make the desired connections. Because of this flexibility, system complexity can range from simple to extremely complex.

The simplest possible controlled system comprises a controller and one Model 8020. The controller is used to send commands to the instrument, which sends data back to the controller.

The system becomes more complex when additional instruments are added. Depending on programming, all data may be routed through the controller, or it may be transmitted directly from one instrument to another.

**4-6-2. Connections**

The instrument is connected to the bus through an IEEE-488.2 connector. This connector is designed to be stacked to allow a number of parallel connections on one instrument.

**NOTE**

To avoid possible mechanical damage, it is recommended that no more than three connectors be stacked on any one instrument. Otherwise, the resulting strain may cause internal damage to the connectors.

The IEEE-488.2 bus is limited to a maximum of 15 devices, including the controller. Also, the maximum cable length is 20 meters. Failure to

Table 4-2. IEEE-488 Contact Designations

Contact Number	IEEE-488 Designation	Type
1	DIO1	Data
2	DIO2	Data
3	DIO3	Data
4	DIO4	Data
5	EOI	Management
6	DAV	Handshake
7	NRFD	Handshake
8	NDAC	Handshake
9	IFC	Management
10	SRQ	Management
11	ATN	Management
12	SHIELD	Ground
13	DIO5	Data
14	DIO6	Data
15	DIO7	Data
16	DIO8	Data
17	REN	Management
18-24	Gnd	Ground

observe these limits will probably result in erratic bus operation.

Custom cables may be constructed using the information in Table 4-2. Table 4-2 also lists the contact assignments for the various bus lines. Contacts 18 through 24 are return lines for the indicated signal lines, and the cable shield is connected to contact 12. Each ground line is connected to digital common in the Model 8020.

**CAUTION**

The voltage between IEEE common and ground must not exceed 0 V or damage may result to your instrument.

**4-7. CHANGING GPIB ADDRESS**

The primary address of your instrument may be programmed to any value between 0 and 30 as long as the selected address is different from other devices addresses in the system. This may be accomplished using a front panel programming sequence. Note that the primary address of the instrument must agree with the address specified in the controller’s program.



**NOTE**

The programmed primary address is briefly displayed during the power-up cycle of the Model 8020. It is stored in the non-volatile memory of the instrument and is retained even when power is turned off.

To check the present address, or to enter a new one, proceed as follows:

1. Depress the [2nd] push-button once then depress the [ADR] push-button. The display will be modified to display the following:

**IExx**

Where x may be any number from 0 to 30.

2. Use the MODIFIER [x1↑] or the [x1 ↓] push-buttons for selecting a new GPIB primary address.

3. To store the newly selected primary address depress [EXE]. The instrument then resumes normal operation.

**4-8. BUS COMMANDS**

While the hardware aspect of the bus is essential, the interface would be essentially worthless without appropriate commands to control the communications between the various instruments on the bus. This paragraph briefly describes the purpose of the bus commands, which are grouped into the following three categories:

**1. Uniline commands:** Sent by setting the associated bus line low (true).

**2. Multiline commands:** General bus commands which are sent over the data lines with the ATN line low (true).

**3. Device-dependent commands:** Special commands that depend on device configuration; sent over the data lines with ATN high (false).

**4. Common commands and queries:** A special set of commands that all devices must use and does not depend on device configuration; sent over the data lines in the same format as the device dependent commands.

**4-8-1. Uniline Commands**

Uniline commands are sent by setting the associated bus line to low. The ATN, IFC, and REN commands are asserted only by the system controller. The SRQ command is sent by an external device. The EOI command may be sent by either the controller or

Table 4-3. IEEE-488 Bus Command Summary

COMMAND TYPE	COMMAND	STATE OF ATN LINE(*)	COMMENTS
<b>Uniline</b>	REN	X	Set up for remote operation
	EOI	X	Sent by setting EOI low
	IFC	X	Clears Interface
	ATN	Low	Defines data bus contents
	SRQ	X	Controlled by external device
<b>Multiline Universal</b>	LLO	Low	Locks out front panel controls
	DCL	Low	Returns device to default conditions
	SPE	Low	Enable serial polling
	SPD	Low	Disables serial polling Addressed
	SDC	Low	Returns unit to default condition
	GTL	Low	Returns to local control
	GET	Low	Triggers device for reading
<b>Unaddress</b>	UNL	Low	Removes all listeners from bus
	UNT	Low	Removes all talkers from bus
<b>Device- Dependent(**)</b>		High	Programs Model 802020 for various modes.

(\*) X = Don't Care, (\*\*) See paragraph 4-9 for complete description

an external device depending on the direction of data transfer. The following is descriptions of each command.

**REN** - (Remote Enable) - The remote enable command is sent to the Model 8020 by the controller to set the instrument up for remote operation. Generally, this should be done before attempting to program the instrument over the bus. The Model 8020 will indicate that it is in the remote mode by illuminating its front panel REM indicator. To place the Model 8020 in the remote mode, the controller must perform the following steps:

1. Set the REN line true.
2. Address the Model 8020 to listen.

#### NOTE

Setting REN true without addressing will not cause the REM indicator to turn on; however, once REN is true, the REM light will turn on the next time an address command is received.

**EOI** (End Or Identify) - The EOI command is used to positively identify the last byte in a multi-byte transfer sequence. This allows variable length data words to be transmitted easily.

**IFC** (Interface Clear) - The IFC command is sent to clear the bus and set hand shake lines to a known state. Although device configurations differ, the IFC command usually places instruments in the talk and listen idle states.

**ATN** (Attention) - The controller sends ATN while transmitting addresses or multiline commands. Device-dependent commands are sent with the ATN line high (false).

**SRQ** (Service Request) - The SRQ command is asserted by an external device when it requires service from the controller. If more than one device is present, a serial polling sequence, as described in paragraph 4-8-2, must be used to determine which has requested service.

#### 4-8-2. Universal Multiline Commands

Universal commands are multiline commands that require no addressing. All instrumentation equipped to implement the command will do so simultaneously when the command is transmitted over the bus. As with all multiline commands, the universal commands are sent over the data lines with ATN set low:

**LLO** (Local Lockout) - The LLO command is sent by the controller to remove the Model 8020 from the local operating mode. Once the unit receives the LLO command, all its front panel controls (except Power) will be inoperative.

#### NOTE

The REN bus line must be true before the instrument will respond to an LLO command.

To lock out the front panel controls of the Model 8020, the controller must perform the following steps:

1. Set ATN true.
2. Send the LLO command to the instrument.

**DCL** (Device Clear) - The DCL command may be used to clear the Model 8020, setting it to a known state. Note that all devices on the bus equipped to respond to a DCL will do so simultaneously. When the Model 8020 receives a DCL command, it will return to the default conditions listed in Table 4-4. Factory pre-selected parameters are listed in Table 3-1. To send a DCL command the controller must perform the following steps:

1. Set ATN true.
2. Place the DCL command on the bus.

**SPE** (Serial Poll Enable) - The serial polling sequence is used to obtain the Model 8020 status byte. Usually, the serial polling sequence is used to determine which of several devices has requested service over the SRQ line. However, the serial polling sequence may be used at any time to obtain the status byte from the Model 8020. For more information on status byte format, refer to paragraph 4-14. The serial polling sequence is conducted as follows:

1. The controller sets the ATN line true.
2. The SPE (Serial Poll Enable) command is placed on the bus by the controller.
3. The Model 8020 is addressed to talk.
4. The controller sets ATN false.
5. The Model 8020 then places its status byte

on the bus to be read by the controller.

6. The controller then sets the ATN line low and places SPD (Serial Poll Disable) on the bus to end the serial polling sequence.

Steps 3 through 5 may be repeated for other instruments on the bus by using the correct talk address for each instrument. ATN must be true when

Table 4-4. Default Conditions. (Status After SDC, DCL, or \*RST )

Mode	Default	Status
Display/Modify	D0	Display frequency
Sweep Mode	S0	Sweep mode off
Offset Mode	O0	Offset mode off
Operating Mode	V0	VCO mode off
Gated Mode	G0	Gated mode off
Trigger Mode	T0	Trigger mode off
Pulse Mode (Model 8021)	P0	Pulse mode off
AM Mode (Model 8022)	A0	Am mode off
Output Mode (Model 8021)	C0	Pulse complement off; Ramp down off
St-by	B0	Output stand-by off
Response Message Format	X0	Response header OFF
Response Message Terminator	Z0	New line(LF), END(EOI) terminator
Event Status Enable Mask	*ESE0	No mask
SRQ Enable Register Mask	*SRE0	No mask

the talk address is transmitted and false when the status byte is read.

**SPD** (Serial Poll Disable) - The SPD command is sent by the controller to remove all instrumentation on the bus from the serial poll mode.

#### 4-8-3. Addressed Commands

Addressed commands are multiline commands that must be preceded by a listen command derived from the device's primary address before the instrument will respond. Only the addressed device will respond to each of these commands:

**SDC** (Selective Device Clear) - The SDC command performs essentially the same function as the DCL command except that only the addressed device will respond. This command is useful for clearing only a selected instrument instead of all devices simultaneously. Model 8020 will return to the default conditions listed in Tables 3-1 and 4-4 when responding to an SDC command. To transmit the SDC command, the controller must perform the following steps:

1. Set ATN true.
2. Address the Model 8020 to listen.
3. Place the SDC command on the data bus.

**GTL** (Go To Local) - The GTL command is used to remove the instrument from the remote mode of operation. Also, front panel control operation will usually be restored if the LLO command was previously sent. To send the GTL command, the controller must perform the following sequence:

1. Set ATN true.
2. Address the Model 8020 to listen.
3. Place the GTL command on the bus.

#### NOTE

The GTL command does not remove the local lockout state. With the local lockout condition previously set, the GTL command will enable front panel control operation until the next time a listener address command is received. This places the Model 8020 in the local lockout state again.

**GET** (Group Execute Trigger) - The GET command is used to trigger or arm devices to perform a specific task depends on device configuration. Although GET is considered to be an addressed command, many devices respond to GET without being addressed. Using the GET command is only one of several methods that can be used to initiate a trigger. More detailed information on triggering can be found in Section 3 of this manual. To send GET command over the bus, the controller must perform the following sequence:

1. Set ATN true.
2. Address the Model 8020 to listen.
3. Place the GET command on the data bus.

GET can also be sent without addressing by omitting step 2.

#### 4-8-4. Unaddress Commands

The two unaddress commands are used by the controller to simultaneously remove all talkers and listeners from the bus. ATN is low when these multiline commands are asserted.

**UNL** (Unlisten) - All listeners are removed from the bus at once when the UNL commands is placed on the bus.

**UNT** (Untalk) - The controller sends the UNT command to clear the bus of any talkers.

#### 4-8-5. Device-dependent Commands

The meaning of the device-dependent commands is determined by instrument configuration. Generally, these commands are sent as one or more ASCII characters that tell the device to perform a specific function. For example, M2 is sent to the Model 8020 to place the instrument in the external trigger mode. The IEEE-488.2 bus treats device-dependent commands as data in providing that ATN is high (false) when the commands are transmitted.

#### 4-8-6. Common Commands and Queries

Since most instruments and devices in an ATE system use similar commands which perform identical functions, the IEEE-488.2 document has specified a common set of commands and queries which all device must use. This avoids the problem in which devices from various manufacturers used a different set of commands to enable functions and report status. The IEEE-488.2 treats the common commands and queries as device dependent commands. For example, \*TRG is sent over the bus to trigger the instrument. Some common commands and queries, however, are optional; most of them are mandatory. The following set of command groups ensure that all devices communicate uniformly:

**1. System Data** - These commands are used to store or retrieve information such as device identification, descriptions and options. It is possible to determine the manufacturer, model, and serial number of the device under remote control.

**2. Internal Operation** - These commands include such instrument operations as resetting, self-calibrating, and self-diagnostics of a GPIB device. The device may respond to a calibration query to indicate that the calibration was carried out successfully and report any calibration errors that may have occurred. The reset command sets the device-dependent functions to a known state and must not affect the state

of the IEEE-488 interface, the Service Request Enable register, or Standard Event Status Enable register.

**3. Status and Event** - These commands control the status structure of the GPIB device and provide a means to read and enable events. Included in these commands are Clear, Event Status Enable, Power-on Status, and Service Request Enable.

**4. Synchronization** - The operation of the devices within the system are synchronized with these commands. Included is a Wait to Continue command which forces the devices to complete all previous commands and queries. The Operation Complete command tells the device to set bit 0 in the Standard Event Status register when it completes all pending operations.

**5. Device Trigger** - These commands enable a device to be triggered and specify how it responds to the trigger message. The Define Device Trigger command stores a sequence of commands which the device will follow when the Group Execute Trigger (GET) is received.

**6. Stored Settings** - These commands are used to save the state of the device under control, to be used at a later time. The Save command stores the present state of the device in the device's memory. If there is more than one location in which this data can be stored, the command is followed by a number which designates the storage register to use. The Recall command restores the state of the device, as stored in its memory from the previous Save command. As with the Save command, the Recall command must be followed by a number to specify the register from which the stored settings are to be recalled.

#### 4-9. DEVICE LISTENING FORMATS

This paragraph discusses the formatting of <Program Message> elements received by a device from its system interface. Allowable IEEE-488.2 <Program Message> is composed of sequence of <Program Message> units, each unit representing a program command. Each program command is composed of a sequence of functional syntactic elements. Legal IEEE-488.2 program commands are created from functional elements sequences.

Some commands of universal instrument system application have been defined by the IEEE-488.2. They are the common commands; these commands and queries are specific path selections through the functional syntax diagram as specified in the IEEE-488.2 standard. The remaining commands are device-specific and are generated by the device designer

using the functional syntax diagram and the needs of the device. The functional elements include separators, terminators, headers, and data types. These elements are discussed in the following.

#### 4-9-1. Functional Element Summary

**<Program Message>** Represents a sequence of zero or more <Program Message Unit> elements separated by <Program Message Unit Terminator> elements.

**<Program Message Unit>** Represents a single command or programming data received by the device.

**<Command Message Unit>** Represents a single command or programming data received by the device.

**<Query Message Unit>** Represents a single query sent from the controller to the device.

**<Program Data>** Represents any of the six different program data types.

**<Program Message Unit separator>** Separates the <Program Message Unit> elements from one another in a <Program Message>.

**<Program Data Separator>** Separates sequential <Program data> elements that are related to the same header.

**<Program Header Separator>** Separates the header from any associated <Program Data>.

**<Program Message Terminator>** Terminates a <Program Message>.

**<Command Program Header>** Specifies function operation. Used with any associated <Program Data elements>.

**<Query Program Header>** Similar to <Command Program Header> except a query indicator (?) shows that a response is expected from the device.

**<Character Program Data>** A data type suitable for sending short mnemonic data, generally where a numeric data type is not suitable.

**<Decimal Numeric Program Data>** A data type suitable for sending decimal integers or decimal fractions with or without exponents.

**<Suffix Program Data>** An optional field following <Decimal Numeric Program Data> used to indicate associated multipliers and units.

**<NonDecimal Numeric Program Data>** A data type suitable for sending integer numeric representation in base 16, 8, or 2. Useful for data that is more easily interpreted when directly expressed in a non-decimal format.

**<String Program Data>** A data type suitable for sending 7-bit ASCII character strings where the content needs to be "Hidden" (by delimiters)

**<Arbitrary Block Program Data>** A data type suitable for sending blocks of arbitrary 8-bit information.

**<Expression Program data>** A data type suitable for sending data that is elevated as one or more non-expression data elements before further parsing.

#### 4-9-2. Separator Functional Element Summary

The various elements within the <Program Message> are separated by ASCII characters that were specially assigned for this purpose. These separators are discussed in the following paragraphs.

##### 4-9-2-1. Program Message Unit Separator

The <Program Message Unit Separator> separates sequential <Program Message Unit> elements from one another within a <Program Message>. The <Program Message Unit Separator> is defined as:

;

It is allowed to use leading <white space> elements before the <Program Message Separator>. <White Space> is defined as a single ASCII-encoded byte in the range of 00-09, 0B-20. This range includes the ASCII control characters and the space, but excludes the new line.

##### 4-9-2-2. Program Data Separator

The <Program Data Separator> separates sequential <Program Data> elements from one another after a <Command Program Header> or <Query Program Header>. It is used when a <Command Program Header> or <Query Program Header> has multiple parameters. The <Program Data Separator> is defined as:

,

Preceding and succeeding <White Space> elements are permitted.

##### 4-9-2-3. Program Header Separator

The <Program Header Separator> separates the <Command Program Header> or <Query Program Header> from the <Program Data> elements. The <Program Header Separator> is defined as white space:

<White Space>

Refer to paragraph 4-9-2-1 for the definition of <White Space> elements.

### 4-9-3. Program Message Terminator

A <Program Message Terminator> terminates a sequence of one or more definite length <Program Message Unit> elements. There are three possible <Program Message Terminator> elements:

1. NL (new line);
2. NL END (EOI); and
3. END (EOI)

NL is defined as a single ASCII-encoded byte 0A (10 decimal). Leading <White Space> elements are permitted. The instrument interprets any and all of the three terminators as semantically equivalent. No alternative encoding are allowed. Note that IEEE-P981 amendment forbids the use of CR as a <Program Message Terminator> element. This is because some controller treat CR as the end of transmission and leave the LF character in the unit, thereby creating an error in the controller.

### 4-9-4. Command Program Header

The <Command Program Header> represents the operation to be performed in a device. The header may be optionally followed by associated parameters encoded as <Program Data> elements. There are three defined <Command Program Header> elements: <Simple Command Program Header>, <Compound Command Program Header>, and <Common Command Program Header>.

<Simple Command Program Header> is defined as:

#### <Program Mnemonic>

For example, FRQ. Leading <White Space> elements are permitted. Upper/lower case alpha characters are treated with the same semantic equivalence. <Compound Command Program Header> is not used in model 8020 and will not be discussed here. A <Common Command Program Header> is defined as:

#### \*<Program Mnemonic>

For example, \*TRG. Leading <White Space> elements are permitted. Upper/ lower case alpha characters are treated with the same semantic equivalence.

### 4-9-5. Query Program Header

The <Query Program Header> represents the operation to be performed in a device. A <Query

Program Header> causes the device to generate a response. This element may be optionally followed by associated parameters encoded as <Program Data> elements. There are three defined <Query Program Header> elements: <Simple Query Program Header>, <Compound Query Program Header>, and <Common Query Program Header>. A <Simple Query Program Header> is defined as:

#### <Program Mnemonic>?

For example, FRQ?. Leading <White Space> elements are permitted. Upper/lower case alpha characters are treated with the same semantic equivalence. <Compound Query Program Header> is not used in model 8020 and will not be discussed here. A <Common Query Program Header> is defined as:

#### \*<Program Mnemonic>?

For example, \*CAL?. Leading <White Space> elements are permitted. Upper/lower case alpha characters are treated with the same semantic equivalence.

### 4-9-6. Program Data

A <Program Data> functional element is used to convey a variety of parameter information related to the <Program Header>.

#### 4-9-6-1. Character Program Data

The <Character Program Data> functional element is not implemented in Model 8020. Therefore it shall not be discussed in this manual.

#### 4-9-6-2. Decimal Numeric Program Data

The <Decimal Numeric Program Data> is a flexible version of the three numeric representations as defined in ANSI X3.42-1975 - NR1, NR2, and NR3. A <Decimal Numeric Program Data> elements are defined as:

1. **NR1** elements consists of a set of implicit point representations of numeric values. i.e. (+/-)12345.

2. **NR2** elements are the representations of explicit point numeric values. i.e. (+/-)12.345.

3. **NR3** elements are representations of scaled explicit radix point numeric values together with an exponent notation. i.e. (+/-)123.456E(+/-)3.

#### 4-9-6-3. Suffix Program Data

A <Suffix Program Data> element permits the use of a suffix following the <Decimal Numeric Program Data> (NRf). The suffix expression associated units and (optional) multipliers that modify how the NRf is interpreted by the device. The presence of a <Suffix Program Data> after an NRf is always optional. No particular <Command Program Header> or <Query Program Header> is a device shall require the use of a <Suffix Program Data> element.

#### 4-9-6-4. Non-Decimal Numeric Program Data

The <Non-Decimal Program Data> functional element is not implemented in Model 8020. Therefore it shall not be discussed in this manual.

#### 4-9-6-5. Arbitrary Block Program Data

The <Arbitrary Block Program Data> functional element is not implemented in Model 8020. Therefore it shall not be discussed in this manual.

#### 4-9-6-6. Expression Program Data

The <Expression Program Data> functional element is not implemented in Model 8020. Therefore it shall not be discussed in this manual.

### 4-10. DEVICE-DEPENDENT COMMAND PROGRAMMING

IEEE-488.2 device-dependent commands are sent to the Model 8020 to control various operating conditions such as display modify, operating mode, output and parameter interrogate. Each command is made up of a program, command or query header followed by program data, program suffix, and terminated by program message terminator. The IEEE bus treats device-dependent commands as data in, providing that ATN is high when the commands are transmitted. For example the output amplitude is programmed by sending the following <Program Message Unit>: AMP 10.5V.

A number of <Program Message Unit> elements may be grouped together in one <Program Message> provided that each <Program Message Unit> is separated by a <Program Message Unit Separator>. <Program message Unit> elements within a <Program Message> are executed exactly in the same order they are received from the controller. The Model 8020 ignores all non-printable ASCII characters (00 HEX through 20 HEX) except the "CR" (carriage

return). A command string is terminated by a <Program Message Terminator> which tells the instrument to execute the <Program Message>.

If an illegal <Program Header> or <Program Data> is present within a <Program Message>, the instrument will:

1. Ignore the illegal part or the <Program Message> (but will execute the rest of the <Program Message>).
2. Display an appropriate front panel error message.
3. Set certain bits in its status registers.
4. Generate an SRQ if programmed to do so.

Device-dependent programming aspects are covered in paragraph 4-8-5 and 4-10.

#### NOTE

Before programming the instrument over the bus, it is recommended that the instrument be set to its default values by sending an SDC or DCL over the bus. See paragraph 4-8-3 for information on using the SDC command.

In order to send a device-dependent or a common command, the controller must perform the following sequence:

1. Set ATN true.
2. Address the Model 8020 to listen.
3. Set ATN false.
4. Send the command string over the data bus one byte at a time.

#### NOTE

REN must be true when attempting to program the Model 8020.

Device-dependent commands that affect Models 8020, 8021, and 8022 are listed in Table 4-5. Common commands and queries are listed in Table 4-6. All the commands listed in the Tables 4-5 and 4-6 are covered in detail in the following.

#### 4-10-1. Display (D)

The display modify command controls what the Model 8020 places on the display. The eight parameters associated with the display command set the instrument to display the frequency, amplitude,

Table 4-5. Device-Dependent Command Summary

<b>Mode</b>	<b>Program Header and Data</b>	<b>Description</b>
<b>Display</b>	VFRQ	Frequency
	VAMP	Amplitude
	VOFS	Offset
	VWID	Pulse Width (model 8021)
	VCAR	Carrier Level (model 8022)
	VSTP	Sweep Stop Frequency
	VSWT	Sweep Time
	VRPT	Internal Trigger Period
	VMRK	Sweep Marker Frequency
VDCO	DC Output Level	
<b>Sweep Mode</b>	S0	Sweep Off
	S1	Log Sweep - Start to Stop (up)
	S2	Log Sweep - Stop to Start (down)
	S3	Log Sweep - Start to Stop to Start
	S4	Log Sweep - Stop to Start to Stop
	S5	Lin Sweep - Start to Stop (up)
	S6	Lin Sweep - Stop to Start (down)
	S7	Lin Sweep - Start to Stop to Start
	S8	Lin Sweep - Stop to Start to Stop
<b>Operating Mode</b>	V0	VCO Mode Off
	V1	VCO Mode On
	A0	Amplitude Modulation Off
	A1	Amplitude Modulation On
	P0	Pulse Width Off
	P1	Pulse Width On
	O0	Offset Off
	O1	Offset On
<b>Trigger Mode</b>	G0	Gate Mode Off
	G1	Gate Mode On
	T0	Trigger Mode Off
	T1	Trigger Mode On - External Trigger
	T2	Trigger Mode On - Internal Trigger
<b>Output Mode</b>	C0 (model 8021)	Pulse Complement Off; Ramp Down Off
	C1 (model 8021)	Pulse Complement On; Ramp Down On
	B0	Output Stand-by Off
	B1	Output Stand-by On



Table 4-5. Device-Dependent Command Summary (continued)

Mode	Header and Data	Description	Suffix* Data
<b>Output Waveforms</b>			
	U0	Sine	
	U1	Triangle	
	U2	Squarewave	
	U3	Fixed base-line positive squarewave	
	U4	Fixed base-line negative squarewave	
	U5	DC; Ramp (Model 8021)	
<b>Program Parameters</b>			
	FRQ	Program output frequency	HZ, KHZ, MHZ
	AMP	Program output amplitude	MV, V
	OFS	Program output offset	MV, V
(Model 8021 only)	WID	Program pulse width	NS, US, MS, S
(Mode 8022 only)	CAR	Program carrier Level	%
	STP	Program sweep stop	HZ, KHZ, MHZ
	SWT	Program sweep time	NS, US, MS, S
	RPT	Program internal trig. generator per.	NS, US, MS, S
	MRK	Program sweep marker	HZ, KHZ, MHZ
(Model 8020 and 8022 only)	DCO	Program dc output level	MV, V
<b>Review Parameters</b>			
	VFRQ	Display output frequency	
	VAMP	Display output amplitude	
	VOFS	Display output offset	
(Model 8021 only)	VWID	Display pulse width	
(Mode 8022 only)	VCAR	Display carrier Level	
	VSTP	Display logarithmic sweep stop	
	VSWT	Display sweep time	
	VRPT	Display internal trig. generator per.	
	VMRK	Display logarithmic sweep marker	
(Model 8020 and 8022 only)	VDCO	Display dc output level	
<b>Response Data Query</b>			
	FRQ?	Interrogate output frequency	HZ, KHZ, MHZ
	AMP?	Interrogate output amplitude	MV, V
	OFS?	Interrogate output offset	MV, V
(Model 8021 only)	WID?	Interrogate pulse width	NS, US, MS, S
(Mode 8022 only)	CAR?	Interrogate carrier Level	%
	STP?	Interrogate sweep stop	HZ, KHZ, MHZ
	SWT?	Interrogate sweep time	NS, US, MS, S
	RPT?	Interrogate internal trig. generator per.	NS, US, MS, S
	MRK?	Interrogate sweep marker	HZ, KHZ, MHZ
(Model 8020 and 8022 only)	DCO?	Interrogate dc output level	MV, V
	STT?	Interrogate machine status	

\* Suffix Data is optional.

Table 4-5. Device-Dependent Command Summary (continued)

Mode	Program Header and Data	Description
<b>Response Message Format</b>		
	X0	Response header OFF
	X1	Response header ON
	Z0	New line (LF), END (EOI) terminator
	Z1	New line (LF) terminator
	Z2	END (EOI) terminator
	Z3	No terminator
<b>Common Commands</b>		
	*CLS	Clear status command
	*ESE	Standard event status enable command
	*OPC	Operation complete command
	*RCL	Recall front panel set-up command
	*RST	Reset command
	*SAV	Save front panel set-up command
	*SRE	Service request enable command
	*TRG	Trigger command
	*WAI	Wait-to-continue command
<b>Common Queries</b>		
	*ESE?	Standard event status enable query
	*ESR?	Standard event status register query
	*IDN?	Identification query
	*OPC?	Operation complete query
	*SRE?	Service request enable query
	*STB?	Read status byte query
	*TST?	Self-test query
<b>STANDARD EVENT STATUS ENABLE REGISTER MASK</b>		
	*ESE0	No mask
	*ESE1	ESB bit set on operation complete
	*ESE2	Not used
	*ESE4	ESB bit set on query error
	*ESE8	ESB bit set on device dependent error
	*ESE16	ESB bit set on execution error
	*ESE32	ESB bit set on command error
	*ESE64	ESB bit set on user request
	*ESE128	ESB bit set on power on
<b>SERVICE REQUEST ENABLE REGISTER MASK</b>		
	*SRE0	No mask
	*SRE1	Not used
	*SRE2	RQS/MSS bit set on offset error
(Model 8021 only)	*SRE4	RQS/MSS bit set on pulse error
(Model 8021 only)	*SRE8	RQS/MSS bit set on ramp error
	*SRE16	RQS/MSS bit set on MAV bit (message available)
	*SRE32	RQS/MSS bit set on ESB bit (standard event status register)
	*SRE128	Not used

offset, pulse width (model 8021), carrier level, sweep stop frequency, sweep time / trigger period or the sweep marker frequency. The display mode may be programmed by sending one of the following commands:

**VFRQ** = Frequency  
**VAMP** = Amplitude  
**VOFS** = Offset  
**VWID** = Pulse Width (model 8021)  
**VCAR** = Carrier Level (model 8022)  
**VSTP** = Sweep Stop Frequency  
**VSWT** = Sweep Time  
**VMRK** = Sweep Marker Frequency  
**VRPT** = Internal Trigger Period

#### 4-10-2. Operating Mode (V, P, A, O)

This command gives the user control over the operating mode of the instrument. The operating mode may be programmed by sending one of the following commands:

**V0** = VCO Mode Off  
**V1** = VCO Mode On  
**P0** = Pulse Mode Off (model 8021)  
**P1** = Pulse Mode On (model 8021)  
**A0** = Amplitude Modulation Mode Off (model 8022 only)  
**A1** = Amplitude Modulation Mode On (model 8022 only)  
**O0** = Offset Mode Off  
**O1** = Offset Mode On

#### 4-10-3. Trigger Mode (G, T)

The trigger mode command gives the user control over the operating mode of the Model 8020. There are a number of acceptable external sources for stimulating the function generator. The instrument may also be set to operate in continuous mode or with having an internal stimulant. The generator may be programmed to accept either an external stimulant or an internal stimulant. Program the Model 8020 to one of the trigger modes by sending one of the following commands:

**G0** = Gated Mode Off  
**G1** = Gated Mode On  
**T0** = Triggered Mode Off  
**T1** = Triggered Mode On - External Trigger  
**T2** = Triggered Mode On - Internal Trigger

#### 4-10-4. Output Mode (C, B)

The output mode command places the function generator in stand by mode. In model 8021 this command places the output in pulse complement mode and in inverted ramp mode. The output mode may be programmed by sending one of the following commands

**C0** = Pulse Complement Off; Ramp Down Off (model 8021)  
**C1** = Pulse Complement On; Ramp Down On (model 8021)  
**B0** = Output Stand-By Off  
**B1** = Output Stand-By On

#### 4-10-5. Waveform (U)

The waveform command give the user control over the output waveform. The six parameters which are associated with the waveform commands, set the instrument to output sinewave, triangle, squarewave, positive pulse, negative pulse, or DC. The waveform may be programmed by sending one of the following commands:

**U0** = Sine  
**U1** = Triangle  
**U2** = Rectangular  
**U3** = Positive Pulse  
**U4** = Negative Pulse  
**U5** = DC; Ramp Up (model 8021)

#### 4-10-6. Parameter Programming

The parameter programming command sets the function generator to the various levels which are required for the unit under test. There are 10 different parameters which may be modified using this command. The command message unit is comprised of three parts: the <command program header>, the <decimal numeric program data>, the <suffix program data> (optional), and the <program message terminator>.

The <command program header> mnemonic is independent of control location on the front panel but relates to front panel nomenclature. For example, FRQ mnemonic is related to front panel Frequency marking.

The <decimal numeric program data> is a flexible version of numeric representation denoted by NRf. Operator may choose to program <decimal numeric program data> using NR1, NR2, or NR3 formats.

Examples of the various <decimal numeric program data> is given in the following.

**NR1** elements consists of a set of implicit point representations of numeric values. i.e. (+/-)12345.

**NR2** elements are the representations of explicit point numeric values. i.e. (+/-)12.345.

**NR3** elements are representations of scaled explicit radix point numeric values together with an exponent notation. i.e. (+/-)123.456E(+/-)3.

The <suffix program data> element permits the use of suffix following the NRf. The suffix expresses associated units and (optional) multipliers that modify how the NRf is interpreted by the device.

For an example, to program the model 8020 for a frequency output of 10.7 MHz, the following <program message unit> options may be used:

FRQ 10700000; or  
FRQ 10.7MHZ; or  
FRQ 10.7E+6; or  
FRQ 10.7E6HZ; etc.

<Command program header> and <suffix program data> and (optional) multipliers summary is given in the following

**FRQ ...HZ, KHZ, MHZ** = Program frequency parameter  
**AMP ...MV, V** = Program amplitude parameter  
**OFS ...MV, V** = Program offset parameter  
**WID ...NS, US, MS, S** = Program pulse width parameter (model 8021 only)  
**CAR ...%** = Program modulated carrier level parameter (model 8022 only)  
**STP ...HZ, KHZ, MHZ** = Program logarithmic sweep stop parameter  
**SWT ...NS, US, MS, S** = Program sweep time parameter  
**MRK ...HZ, KHZ, MHZ** = Program logarithmic sweep marker parameter  
**RPT ...NS, US, MS, S** = Program internal trigger generator period parameter  
**DCO ..MV, V** = Program DC output level (models 8020 and 8022 only)

The programming limits for each of the above parameters are listed in Table 3-2. After DCL or SDC, the instrument defaults to its factory selected values. Factory defaults are listed in Table 3-1 and 4-4.

#### 4-10-7. Common Commands

As discussed in previous paragraphs most instruments and devices in an ATE system use similar commands which perform identical functions to avoid the problem in which devices from various manufacturers used a different set of commands to enable functions and report status. Some common commands and queries, however, are optional; most of them are mandatory. Common commands and queries are listed in Table 4-6. The following set of common commands are utilized in the model 8020 (optional common commands that are not included in the model 8020 command set will not be discussed here).

**\*CLS** (Clear Status Command) - clears status data structures, and forces the device to the Operation Complete Command/Query Idle State. If the Clear Status command immediately follows a <Program Message Terminator>, the Output Queue and the MAV bit will be cleared.

**\*ESE** (Standard Event Status Enable Command) - followed by a number in the range of 0 to 255, sets the Standard Event Status Enable Register bits. The binary equivalent of the number represents the values of the individual bits set into the Standard Event Status Enable register.

**\*OPC** (Operation complete Command) - causes the device to generate the operation complete message in the Standard Event Status Register when all pending selected device operations have been finished.

**\*RCL** (Recall Command) - restores the state of the device to a state previously stored in the device's memory. If the device has more than one memory register, the command must be followed by a number to specify which register is to be used. The functions restored by the \*RCL command are the same as those affected by the \*RST command. Model 8020 may recall settings in registers designated with numbers from 00 to 30.

**\*RST** (Reset) - Sets device-dependent functions to a known state, purges all \*OPC commands and queries, and aborts all pending operations. The output queue, Service Request Enable Register, Standard Event Status Enable Register, and power-on flag are not affected. Device defaults are listed in Table 4-4

**\*SAV** (Save Command) - allows the user to store the present state of a device in local memory. If the device has more than memory location, the command must be followed by a number to designate the storage register to be used. Model 8020 may

store settings in registers designated with numbers from 00 to 30.

**\*SRE** (Service Request Enable Command) - followed by a number, sets the Service Request Enable register which determines what bit in the status byte will cause a service request from the device. The binary equivalent of the number represents the values of the individual bits of the Service Request Enable Register.

**\*TRG** (Trigger Command) - has exactly the same effect as a GET when received, parsed, and executed by the device.

**\*WAI** (Wait to Continue Command) - causes a device to wait until all previous commands and queries are completed before executing any which follow the \*WAI command.

#### 4-10-7-1. Set-ups (\*SAV, \*RCL)

The setups commands select the memory location where front panel setup is to be stored (\*SAV) or from where recalled (\*RCL). To store or recall a setup use one of the following commands:

**\*SAVnn**

**\*RCLnn**

Where nn may range from 00 to 30. nn is the selected memory cell of which the setup is to be stored or from where the setup is to be recalled.

#### 4-11. DEVICE TALKING FORMATS

This paragraph discusses the formatting of <Response Message> elements sent from a device via its system interface. Allowable IEEE-488.2 response message is composed of a sequence of <Response Message> units, each unit representing a response to a query. Each <Response Message> is composed of a sequence of functional syntactic elements. Legal IEEE-488.2 <Response Message> is created from functional elements sequences. A <Response Message is interpreted by a controller running an application program, and as such, needs to convey its information precisely for consistent operation with a wide range of controllers. A <Response Message>, therefore, has a more restrictive format than a <Program Message>.

Some queries of universal instrument system application have been defined by the IEEE-488.2. They are the common queries; these queries are specific path selections through the functional syntax diagram as specified in the IEEE-488.2 standard. The remaining queries are device-specific and are generated by the device designer using the functional syntax diagram and the needs of the device. The functional elements include separators, terminators, headers, and data types. These elements are discussed in the following.

Table 4-6. Common Commands and Queries Summary

Mode	Program Header and Data	Suffix* Data	Description
<b>COMMON COMMANDS</b>	*CLS		Clear status command
	*ESEn		Standard event status enable command
	*OPC		Operation complete command
	*RCLn		Recall front panel set-up command
	*RST		Reset command
	*SAVn		Save front panel set-up command
	*SREn		Service request enable command
	*TRG		Trigger command
	*WAI		Wait-to-continue command
<b>COMMON QUERIES</b>	*ESE?		Standard event status enable query
	*ESR?		Standard event status register query
	*IDN?		Identification query
	*OPC?		Operation complete query
	*SRE?		Service request enable query
	*STB?		Read status byte query
	*TST?		Self-test query

#### 4-11-1. Functional Element Summary

**<Response Message>** Represents a sequence of one or more <Response Message Unit> elements separated by <Response Message Unit Terminator> elements.

**<Response Message Unit>** Represents a single message unit sent from the device.

**<Response Data>** Represents any of the eleven different <Response Data> types.

**<Response Message Unit Separator>** Separates <Response Message Unit> elements from one another in a <Response Message>.

**<Response Data Separator>** Separates sequential <Response Data> elements that are related to the same header or to each other.

**<Response Header Separator>** Separates the header from the associated <Response Data>.

**<Response Message Terminator>** Terminates a <Response Message>.

**<Response Header>** Specifies the function of the associated <Response Data> element(s). Alpha characters mnemonically indicate the function.

**<Character Response Data>** A data type suitable for sending short mnemonic character strings. Generally used when a numeric data type is not suitable.

**<Decimal Numeric Response Data>** A data type response suitable for sending decimal integers or decimal fractions with or without exponents.

**<NonDecimal Numeric Response Data>** A data type suitable for sending integer numeric representation in base 16, 8, or 2. Useful for data that is more easily interpreted when directly expressed in a non-decimal format.

**<String Response Data>** A data type suitable for sending 7-bit ASCII character strings where the content needs to be "Hidden" (by delimiters). This element is generally used to send data for direct display on a device.

**<Definite Length Arbitrary Block Response Data>** A data type suitable for sending blocks of arbitrary 8-bit information when the length is known beforehand.

**<Indefinite Length Arbitrary Block Response Data>** A data type suitable for sending blocks of arbitrary 8-bit information when the length is not known beforehand or when computing the length beforehand is undesirable.

**<Arbitrary ASCII Response data>** A data type suitable for sending arbitrary ASCII data bytes when alternate data types are unworkable.

#### 4-11-2. Separator Functional Element Summary

The various elements within the <Response Message> are separated by ASCII characters that were specially assigned for this purpose. These separators are discussed in the following paragraphs.

##### 4-11-2-1. Response Message Unit Separator

The <Response Message Unit Separator> separates sequential <Response Message Unit> elements from one another when multiple <Response Message Unit> elements are sent in a <Response Message>. The <Response Message Unit Separator> is defined as:

;

##### 4-11-2-2. Response Data Separator

The <Response Data Separator> separates sequential <Response Data> elements from one another when multiple data elements are sent. The <Response Data Separator> is defined as:

,

##### 4-11-2-3. Response Header Separator

The <Response Header Separator> separates the <Response Header> from the <Response Data>. The <Response Header Separator> is defined as:

<Space>

##### 4-11-3. Response Message Terminator

The <Response Message Terminator> element's function is to terminate a sequence of one or more <Response Message Unit> elements. There are three possible <Response Message Terminator> elements:

1. NL (new line);
2. NL END (EOI); and
3. END (EOI)

NL is defined as a single ASCII-encoded byte 0A (10 decimal). Leading <White Space> elements are not permitted. The instrument interprets any and all of the three terminators as semantically equivalent. No alternative encoding are allowed. Note that IEEE-P981 amendment forbids the use of CR as a <Response Message Terminator> element. This is because some controller treat CR as the end of transmission and leave the LF character in the unit, thereby creating an error in the controller.

#### 4-11-4. Response Header

The <Response Header> is available for use by the device designer for device-specific responses. It may be used, for example, to create responses in directly resendable <Program Message Unit> format or to identify response data to the controller. There are three defined <Response Header> elements: <Simple Response Header>, <Compound Response Header>, and <Common Response Header>. A <Simple Response Header> is defined as:

##### <Response Mnemonic>

For example, FRQ. Leading <White Space> elements are not permitted. Upper/lower case alpha characters are treated with the same semantic equivalence. <Compound Response Header> is not used in model 8020 and will not be discussed here. A <Common Response Header> is defined as:

##### \*<Response Mnemonic>

For example, \*SRE. Leading <White Space> elements are not permitted. Upper/ lower case alpha characters are treated with the same semantic equivalence.

#### 4-11-5. Response Data

A <Response Data> functional element is used to convey a variety of response information related to the <Response Header>. The element type is determined by the eliciting query. <Non-Decimal Response Data>, <String Response Data>, and <Arbitrary Block Response Data> functional elements are not implemented in Model 8020. Therefore it shall not be discussed in this manual.

##### 4-11-5-1. Character Response Data

The <Character Response Data> functional element is used to convey information best expressed mnemonically as a short alpha or alphanumeric string. It is useful when numeric parameters are inappropriate, for example, model number and manufacturer identification.

##### 4-11-5-2. Decimal Numeric Response Data

The <Decimal Numeric Response Data> is a flexible version of the three numeric representations as defined in ANSI X3.42-1975 - NR1, NR2, and NR3. A <Decimal Numeric Response Data> elements are defined as:

1. **NR1** elements consists of a set of implicit point representations of numeric values. i.e. (+/-)12345.

2. **NR2** elements are the representations of explicit point numeric values. i.e. (+/-)12.345.

3. **NR3** elements are representations of scaled explicit radix point numeric values together with an exponent notation. i.e. (+/-)123.456E(+/-)3.

#### 4-12. READING FROM THE MODEL 8020

The reading sequence is used to obtain, from Model 8020, various <Response Message Units> such as frequency, amplitude, offset or operating modes. The <Response Message Unit> elements are placed in an output queue. The output queue may be read by device-defined queries. Such device-defined queries cause the item read to be removed from the output queue. Model 8020 executes the <Program Message> elements in the order received. The output is cleared when any of the following occur:

1. Reading all the items in the output queue.
2. Upon receipt of a new <Program Message>.
3. Upon receipt of the \*CLS, DCL or SDC commands.
4. Upon Power on.

IEEE-488.2 specifies that a device cannot send <Response Message> elements unless commanded to do so. This is specified as an "Unterminated Action". The "Unterminated Action" is executed when the controller attempts to read a <Response Message> from the device without first having sent a complete Query Message, including the <Program Message Terminator>, to the device. In the event of "Unterminated Action" model 8020 performs the following steps:

1. Sets the Query Error bit in the Standard Event Status Register.
2. Clears the output queue.
3. Sets brq False.

If a read sequence is interrupted by a new <Program Message> before it finishes sending a <Response Message>, model 8020 executes an "Interrupted Action". GPIB bus response is similar to the "Unterminated Action".

The reading sequence is conducted as follows:

1. The controller sets the ATN line true.
2. The Model 8020 is addressed to talk.
3. The controller sets ATN false.

4. The instrument sends the information string over the bus one byte at a time.
5. The controller recognizes that the string is terminated.
6. The controller sets the ATN line true.
7. The UNT (untalk) command is placed on the bus by the controller.

#### 4-12-1. Interrogate Parameter Data Query

The interrogate parameter data query allows access to information concerning present operating conditions of the instrument. When the interrogate parameter data query is given, the Model 8020 will transmit appropriate data string information the next time the instrument is addressed to talk. Model 8020 Interrogate Parameter Data Query include:

- FRQ?** = Interrogate output frequency parameter  
**AMP?** = Interrogate output amplitude parameter  
**OFS?** = Interrogate output offset parameter  
**WID?** = Interrogate pulse width parameter (model 8021 only)  
**CAR?** = Interrogate Carrier level parameter (model 8022 only)  
**STP?** = Interrogate logarithmic sweep parameter (model 8020 only)  
**SWT?** = Interrogate sweep time parameter (model 8020 only)  
**MRK?** = Interrogate logarithmic sweep marker parameter (model 8020 only)  
**RPT?** = Interrogate internal trigger generator period parameter  
**DCO?** = Interrogate dc output level parameter (model 8020 and 8022 only)  
**RPT?** = Interrogate trigger period parameter  
**STT?** = Interrogate machine status

For example, model 8020 is asked to return frequency, amplitude, and offset parameters in a single <Response Message>

Command: FRQ?;AMP?  
 Response:FRQ 1.000E+3;AMP 1.00E+0

Table 4-7 shows the general <Response Message> format for each of the above commands. Default values are shown. These defaults are generated after an SDC or DCL commands.

#### 4-12-2. Common Queries

As discussed in previous paragraphs most instruments and devices in an ATE system use similar commands which perform identical functions to avoid the problem in which devices from various manufacturers

used a different set of commands to enable functions and report status. Some common commands and queries, however, are optional; most of them are mandatory. The following set of common queries are utilized in the model 8020 (optional common queries that are not included in the model 8020 command set will not be discussed here).

**\*IDN?** (Identification Query) - Causes the generator to respond with its identity. The returned data is organized into four fields, separated by commas. The unit must respond with its manufacturer and model number in the first two fields and may also report its serial number and options in field three and four. If the later information is not available, the device must return an ASCII 0 for each. For example, model 8021 response to \*IDN? is TA-BOR,8021,0,REV2.0.

**\*OPC?** (Operation Complete Query) - causes the device to generate the operation complete message in the Standard Event Status Register when all pending selected device operations have been finished.

**\*SRE?** (Service Request Enable Query) - enables the user to read the contents of the Service Request Enable register. The device returns a number in the range of 0 to 63 or 128 to 191, since bit 6 (RSQ) cannot be set. The binary equivalent of the number represents the value of the bits of the Service Request Enable Register.

**\*STB?** (Read Status Byte Query) - Reads the status byte containing the master summary status (MSS) bit. The device responds with an integer in the range of 0 to 255, whose binary equivalent represents the value of the bits of the status byte.

**\*TST?** (Self-Test Query) - Tells the device to perform an internal self-test and report back to the controller if any errors are detected. The generator responds to this query with a number. A value of 1 in the response indicates that the self-test routine has detected an error. A value of 0 in the response indicates that the self-test was carried out successfully.

#### 4-12-3. Response Header (X)

The <Response Header> from the <Response Message> string may be suppressed using this command. When the <Response Header> is suppressed the output data string is 3 byte shorter. The <Response Header> may be suppressed using the following commands:

- X0** = Response header OFF  
**X1** = Response header ON



#### 4-12-4. Response Message Terminator (Z)

To allow a wide variety of controllers to be used, the terminator can be changed by sending the appropriate command over the bus. The default value is New Line (LF), End (EOI) sequence (mode Z0). The terminator sequence will assume this default value after receiving a DCL or SDC.

The EOI (END) line on the bus is usually set low by the device during the last byte of its data transfer sequence. In this way, the last byte is properly identified, allowing variable length data words to be transmitted. The Model 8020 will normally send EOI during the last byte of its data string or status word. The <Response Message Terminator> in model 8020 may be programmed by sending one of the following commands:

- Z0** = New Line (LF), END (EOI) terminator
- Z1** = New Line (LF) terminator
- Z2** = END (EOI) terminator
- Z3** = No terminator

#### NOTES

1. Most controllers use the LF character to terminate their input sequence. Using the NO TERMINATOR mode (Z3) may cause the controller to hang up unless special programming is used.
2. Some controllers may require that EOI be present at the end of the string.

#### 4-13. DEVICE STATUS REPORTING

Device status reporting defined by IEEE-488.2 builds upon and extends the original specifications of the status byte of the IEEE-488.1 document. A complete model is defined for all status reporting. Figure 4-3 illustrates the IEEE-488.2 status reporting model showing the IEEE-488.1 status byte, which can be read by either a serial poll or Status Byte Query. Summary of related common commands and queries is given in the following.

**\*STB?** - Returns an NR1, which is the value of the IEEE-488.1 status byte and the MSS (Muster Summary Status) summary message.

**\*OPC** - Sets the Operation Complete event bit in the Standard Event Status Register when all selected pending device operation have been completed.

**\*OPC?** - Places a "1" in the output queue when all selected pending operations are completed which in turn cause the MAV (Message Available) summary message to be generated.

**\*CLS** - Clears all Event Registers summarized in the status byte.

**\*ESR?** - Returns an NR1, which is the value of the Standard Event Status Enable Register.

**\*SRE NRf** - Sets the bits of the Service Request Enable Register.

**\*SRE?** - Returns an NR1, which is the value of the Service Request Enable Register.

#### 4-14. STATUS BYTE REGISTER (STB)

The Status Byte Register contains the device's STB and RQS (or MSS) messages. IEEE-488.1 defines the method of reporting the STB and RQS, but leaves the setting and clearing protocols and semantics for the STB message undefined. The standard further defines specific device STB summary-messages.

A Muster Summary Status (MSS) message is also provided which is output as bit 6 with the STB response to a \*STB? common query. The Status Byte Register is altered only when the state of the overlaying Status Data Structure is altered. The description of the various bits within the Status Byte Register is given in the following.

**Bit 0** - Not Used

**Bit 1** - Offset Error. The state of this bit indicates whether or not an offset error occurred. Offset error may occur when amplitude and offset parameters exceed the instrument limits and the offset function is turned on.

**Bit 2** - Width Error. The state of this bit indicates whether or not a pulse width error have occurred. Width error may occur when the programmed pulse width is larger than the programmed pulse period parameter.

**Bit 3** - Ramp Error. The state of this bit indicates whether or not a ramp error have occurred. Ramp error may occur when ramp parameters exceed the instrument limits.

**Bit 4** - Message Available Queue Summary Message (MAV). The state of this bit indicates whether or not the output queue is empty. The MAV summary-message is true when the output queue is not empty. This message is used to synchronize information exchange with the controller. The controller can, for example, send a query command to the device and then wait for MAV to become true. If an application program begins a read operation of the output queue without first checking for MAV, all system bus activity is held up until the device responds.

**Bit 5** - Standard Event Status Bit (ESB) Summary Message. The ESB summary message is an IEEE-488.2 defined message. Its state indicates whether or not one or more of the enabled ESB events have occurred since the last reading or clearing of the Standard Event Status Register.

**Bit 6** - Master Summary Status (MSS)/Request Service (RQS) Bit. Its state indicate if the device has at least one condition to request service. The MSS bit is not part of the IEEE-488.1 status byte and will not be sent in response to a serial poll. The RQS bit, however, if set, will be sent in response to a serial poll.

**Bit 7** - Not used.

**4-14-1. Reading the Status Byte Register**

The Status Byte Register can be read with either a serial poll or the \*STB? common query. Both of these methods read the IEEE-488.1 STB message. The value sent for the bit 6 position is, however, dependent upon the method used.

**4-14-1-1. Reading with a Serial Poll**

When serial polled, the generator returns the 7-bit status byte plus the single bit RQS message. The status bye and RQS message are returned to the controller as a single data byte. The RQS message is sent on line D107 (bit 6). RQS TRUE means that bit 6 line is asserted (pulled to a low voltage) when the status byte is sent. The response represents the sum of the binary-weighted values of the Status Byte Register.

Reading the Status Byte Register with a serial poll sets the RQS message FALSE until a new reason for service has occurred. The STB portion of the Status Byte Register is read non-destructively. The value of the status byte is not altered by a serial poll. Once the model 8020 has generated an RQS, its status byte should be read to clear the SRQ line so the controller can detect an SRQ from another device. Otherwise the instrument will continuously assert the SRQ line.

**4-14-1-2. Reading with the \*STB?**

The \*STB? common query causes the generator to send the contents of the Status Byte Register and the MSS (Master Summary Status) summary message as a single <NR1 Numeric Response Message> element. The response represents the sum of the

Table 4-7. Response Message Format Summary

Command	Response Format (*)
FRQ?	FRQ 1.000E+3(terminator)
AMP?	AMP 1.00E+0(terminator)
OFS?	OFS 0.00E+0(terminator)
WID?	WID 10.00E-3(terminator)
CAR?	CAR 100E+0(terminator)
STP?	STP 9.000E+3(terminator)
SWT?	SWT 1.00E+0(terminator)
MRK?	MRK 5.000E+0(terminator)
DCO?	DCO 0.00E+0(terminator)
RPT?	RPT 1.00E+0(terminator)

(\*) NL END is normal terminator. Terminator may change (see paragraph 4-12-4).

binary-weighted values of the Status Byte Register. The \*STB? common query does not alter the status byte.

**4-14-1-3. Clearing the Status Byte Register**

The entire Status Byte Register can be cleared by removing the reasons for service from the Auxiliary Status Registers. Sending the \*CLS common command to the device after a <Program Message Terminator> and before <Query Message Unit> elements clears the Standard Event Status Register and clears the output queue of any unread messages. With the output queue empty, the MAV summary message is set to FALSE.

Methods of clearing the other auxiliary status registers are discussed in the following. The RQS message in the Status Byte Register will be FALSE. The use of the IEEE-488.1 DCL or SDC commands another method of clearing the Status Byte Register, however, in some cases it is not recommended to use this method since the entire front panel set-up is reset to factory default values.

**4-14-1-4. Service Request Enable Register**

The Service Request Enabling Register is an 8-bit register that enables corresponding summary messages in the Status Byte Register. Thus, the application programmer can select reasons for the model 8020 to issue a service request by altering the contents of the Service Request Enable Register.

The Service Request Enable Register is read with the \*SRE? common query. The response to this query is an number that represents the sum of the binary-weighted value of the Service Request Enable Register. The value of the unused bit 6 is always zero.

The Service Request Enable Register is written using the \*SRE common command followed by a <Decimal Numeric Program Data> element representing the bit values of the Register. A bit value one indicates an enabled condition. Consequently, a bit value of zero indicates a disabled condition. The Service Request Enable Register is cleared by sending \*SRE0. The generator always ignores the value of bit 6. Summary of \*SRE messages is given in the following.

- \*SRE0 - No mask.
- \*SRE1 - Not used.
- \*SRE2 - Service request on offset error.
- \*SRE4 - Service request on pulse width error.
- \*SRE6 - Service request on ramp.
- \*SRE16 - Service request on MAV.
- \*SRE32 - Service request on ESB.
- \*SRE128 - Not used.

#### 4-14-2. Standard Event Status Register (ESR)

The Standard Event Status Register is a special application of the status reporting. IEEE-488.2 document specifies the meaning of each bit of this register. The 8 bits of the ESR have been defined by the IEEE-488.2 as specific conditions which can be monitored and reported back to the user upon request.

The Standard Event Status Register is destructively read with the \*ESR? common query. The Standard Event Status Register is cleared by a \*CLS common command, on power-on, and when read by \*ESR?.

The arrangement of the various bits within the register is firm and is required by all GPIB instruments that implement the IEEE-488.2. Description of the various bits is given in the following.

**Bit 0** - Operation Complete. Generated in response to the \*OPC command. It indicates that the device has completed all selected and pending operations and is ready for a new command.

**Bit 1** - Request Control. This bit operation is disabled on model 8020.

**Bit 2** - Query Error. This bit indicates that an attempt is being made to read data from the output queue when no output is either present or pending.

**Bit 3** - Device Dependent Error. This bit is set when an error in a device function occurs. For example, the following <Program Message> will cause DDE error: AMP10E+0;OFS10E+0. Both parameters are legal and within the specified limits, however, the function generator is unable to generate such an amplitude and offset combination. Following the Device Dependent Error the generator continues to process the input stream.

**Bit 4** - Execution Error. This bit is generated if the <Program Data> element following the header is outside of the legal input range of the generator.

**Bit 5** - Command Error. This bit indicates the generator received a command that was a syntax error, or a command that the device does not implement. A GET receive inside a <Program Message> will also cause a Command Error.

**Bit 6** - User Request. This event bit indicates that one of a set of local controls, the MANUAL push-button in this case, has been activated. This event bit occurs regardless of the remote or local state of the device.

**Bit 7** - Power On. This bit indicates that the device's power source was turned off, then on, since the last time that the register was read.

#### 4-14-2-1. Standard Event Status Enable Register (ESE)

The Standard Event Status Enable Register allows one or more events in the Standard Event Status Register to be reflected in the ESB summary-message bit. The Standard Event Status Enable Register is an 8-bit register that enables corresponding summary messages in the Standard Event Status Register. Thus, the application programmer can select reasons for the model 8020 to issue a ESB summary-message bit by altering the contents of the ESE Register.

The Standard Event Status Enable Register is read with the \*ESE? common query. The response to this query is an number that represents the sum of the binary-weighted value of the Standard Event Status Enable Register.

The Standard Event Status Enable Register is written using the \*ESE common command followed by a <Decimal Numeric Program Data> element representing the bit values of the Register. A bit value one indicates an enabled condition. Consequently, a bit value of zero indicates a disabled condition. The Standard Event Status Enable Register

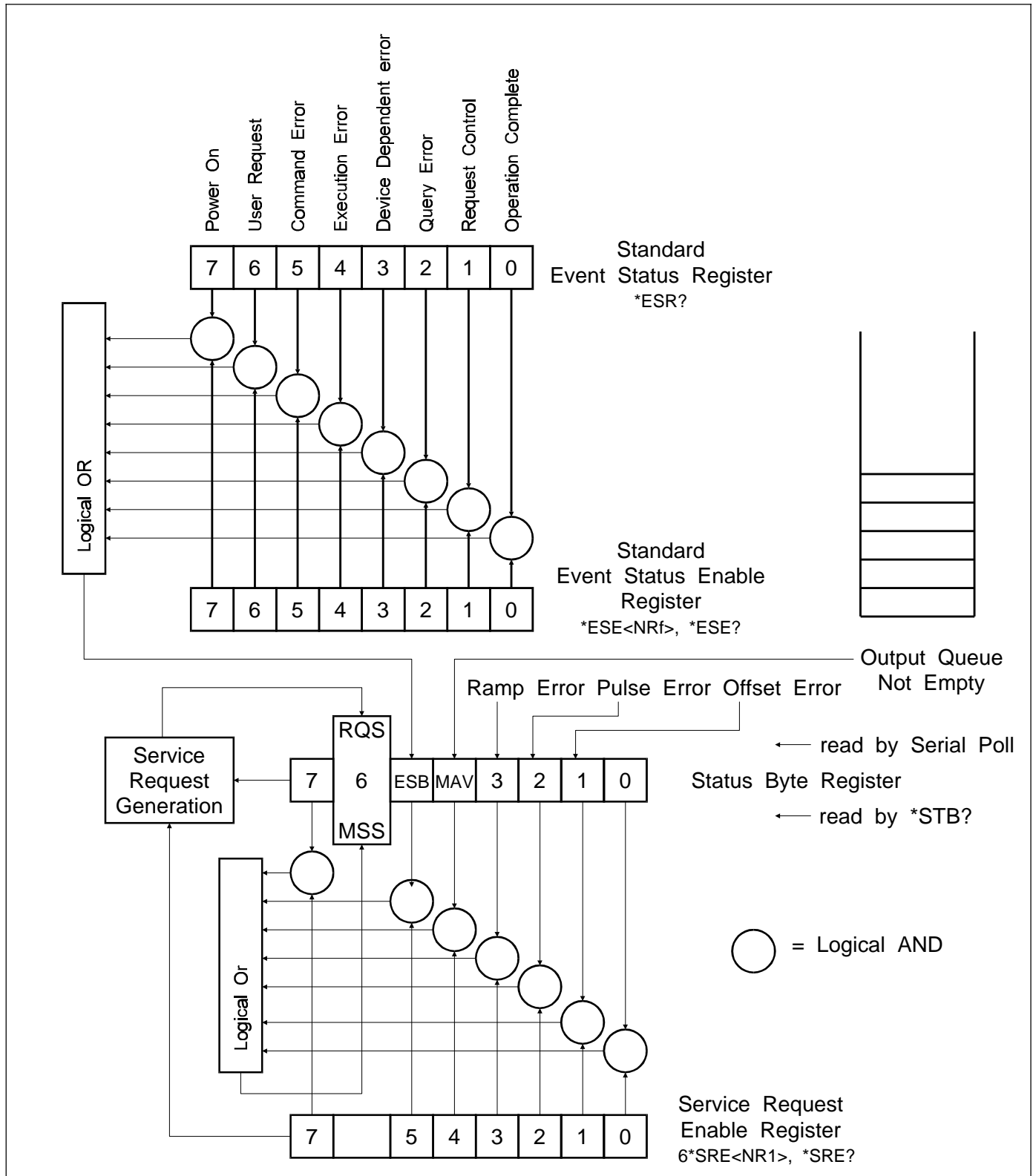

Figure 4-3. IEEE-488.2 Status Reporting Model

is cleared by sending \*ESE0. Summary of \*ESE messages is given in the following.

- \*ESE0 - No mask.
- \*ESE1 - ESB on Operation Complete.
- \*ESE2 - ESB on Request Control.
- \*ESE4 - ESB on Query Error.
- \*ESE6 - ESB on Device Dependent Error.
- \*ESE16 - ESB on Execution Error.
- \*ESE32 - ESB on Command Error.
- \*ESE64 - ESB on User Request.
- \*ESE128 - ESB Power on.

#### 4-14-3. Machine Status Register (STT)

The Machine Status Register (STT) is a special register which contain the present front panel setting. The STT is non-destructively read with the STT? query. The response to this query is a NR1 <Numeric Response Data> with the length of 11 digits. These digits are numeric representation of the various Machine Status options as illustrated in Figure 4-6.

#### 4-15. FRONT PANEL ERROR MESSAGES

The process of programming the Model 8020 involves the proper use of syntax. Syntax is defined as the orderly or systematic arrangement of programming commands or languages. The Model 8020 must receive valid commands with proper syntax or it will:

1. Ignore the part of the <Program Message Unit> in which the invalid command appears.
2. Set appropriate bits in the Standard Event Status Register.
3. Generate an SRQ if programmed to do so.
4. Display an appropriate front panel message.

#### 4-15-1. ILI (Illegal Instruction) Error

An ILI error results when the Model 8020 receives an invalid <Program Header> such as AMPL1.00. This command is invalid because the real command should read AMP1.00. When such an illegal <Program Header> is detected by the instrument, the following message will be displayed on the Model 8020 for about one second:

ILI

#### 4-15-2. ILP (Illegal Parameter) Error

An ILP error occurs when the <Numeric Data> parameter associated with a legal <Program Header> command is not valid. For example, the command AMP100E+0 is not a valid option because the required amplitude is outside the legal limits of the model 8020. When such an illegal <Numeric Data> is detected, the following message will be displayed on the Model 8020 for about one second:

ILP

#### 4-15-3. ILE (Device Dependent) Error

An ILE error occurs when two legal <Program Message> elements and when both elements have legal <Program data> cause unacceptable conditions for the instrument. For example, AMP10E+0; OFS6E+0 <Program Message> will cause an ILE error although each <Program Message Unit> by itself could work perfectly well under different condition. When such an error is detected, the following message will be displayed on the Model 8020 for about one second:

ILE

Figure 4-6. Machine Status String (STT) Interpretation \*

<Program Header>	D	S	O	V	G	T	P/A	C	B	U	X	Z
<Program Data>	0	0	0	0	0	0	0	0	0	0	0	0

\* Status given after IEEE-488.1 DCL or SDC commands, or afetr IEEE-488.2 \*RST common command.

## SECTION 5

### MAINTENANCE AND PERFORMANCE TESTS

#### 5-1. INTRODUCTION

This section provides maintenance, service information, and performance tests for the 8020 series and for the GPIB option (option 1). Fuse replacement procedure, line voltage selection and option installation procedure are also included.

**WARNING**

The procedures described in this section are for use only by qualified service personnel. Do not perform these procedures unless qualified to do so. Many of the steps covered in this section may expose the individual to potentially lethal voltages that could result in personal injury or death, if normal safety precautions are not observed.

#### 5-2. LINE VOLTAGE SELECTION

The Model 8020 may be operated from either 115 V or 230 V nominal 50- 60 Hz power sources. A special transformer may be installed for 100 V and 200 V ranges. The instrument was shipped from the factory set for an operating voltage of 230 V. To change the line voltage, proceed as follows:

**WARNING**

Disconnect the Model 8020 from the power cord and all other sources before changing the line voltage setting.

1. Using a flat-blade screwdriver, place the line voltage selection switch in the desired position. The selected voltage is marked on the selection switch.
2. Install a power line fuse consistent with the operating voltage. See paragraph 5.3.

**CAUTION**

The correct fuse type must be used to maintain proper instrument protection.

#### 5-3. FUSE REPLACEMENT

The Model 8020 has a line fuse to protect the instrument from excessive current. This fuse may be replaced by using the procedure described in the following :

**WARNING**

Disconnect the instrument from the power line and from other equipment before replacing the fuse.

1. Place the end of a flat-blade screwdriver into the slot in the LINE FUSE holder on the rear panel. Push in and rotate the fuse carrier one quarter turn counterclockwise. Release the pressure on the holder and its internal spring will push the fuse and the carrier out of the holder.
2. Remove the fuse and replace it with the proper type using Table 5-1 as a guide.

**CAUTION**

Do not use a fuse with a rating higher than specified or instrument damage may occur. If the instrument persistently blows fuses, a problem may exist within the instrument. If so, the problem must be rectified before continuing operation.

#### 5-4. GPIB INTERFACE OPTION FIELD INSTALLATION (option 1)

The GPIB (general purpose interface bus) option when installed permit a connection to an A.T.E bus controllable system. Detailed information on the IEEE488 standard is

Table 5-1. Line Fuse Selection

<b><u>POWERLINE</u></b>	<b><u>VOLTAGE</u></b>	<b><u>FUSE TYPE</u></b>
90 - 125V	0.63A, 250V	5x20 mm
195 - 250V	0.315A, 250V,	5x20 mm

available in Section 4 of this manual. If purchased with the Model 8020, the option will be factory installed; however the instrument may easily be upgraded in the field by installing the option as described in the following procedure.

**5-4-1. Option 1 Installation Procedure**

1. Remove the top cover of the instrument as described in the disassembly instructions in paragraph 5-5.

**WARNING**

Disconnect the line cord and test leads from the instrument before removing the top cover.

2. Assemble U47 (8291), U48 (75160) and U49 (75161) as shown in Figure 5-1.
3. Remove the small plate that covers the rear panel GPIB opening.
4. Place the GPIB connector onto the rear panel and bolt the special spacers which are provided with this option, to the rear panel. It is important to position the GPIB connector exactly in the center of the opening otherwise the mating connector will not fit. Also only use the special spacing screws that are supplied with this option. Use lock-washers to prevent the option from loosening during transit.
5. Plug the loose end of the flat cable to J2 and press the connector to secure it to its place. Make sure that the cable

is positioned properly, that pin 1 is connected to pin 1 on the main board and that no pin on the main board is left free.

6. Replace the top cover.
7. Turn on the power and observe the power up procedure. The instrument will display the following as part of its power-up procedure:

**Opt.1**

This reading indicates that the instrument accepted the installed option and is now ready to operate on a bus controlled system.

**5-5. DIASSEMBLY INSTRUCTIONS**

If it is necessary to troubleshoot the instrument or replace a component, use the following disassembly procedure to remove the top cover:

1. Remove the two screws that secure the top cover to the rear panel.
2. Grasp the top cover at the rear and carefully lift it off the instrument. When the tabs at the front of the cover clear the front panel, the cover may be pulled completely clear.
3. When replacing the top cover, reverse the above procedure; be sure to install the tabs at the front panel before completely installing the cover.

Figure 5-1. GPIB Interface Option Installation

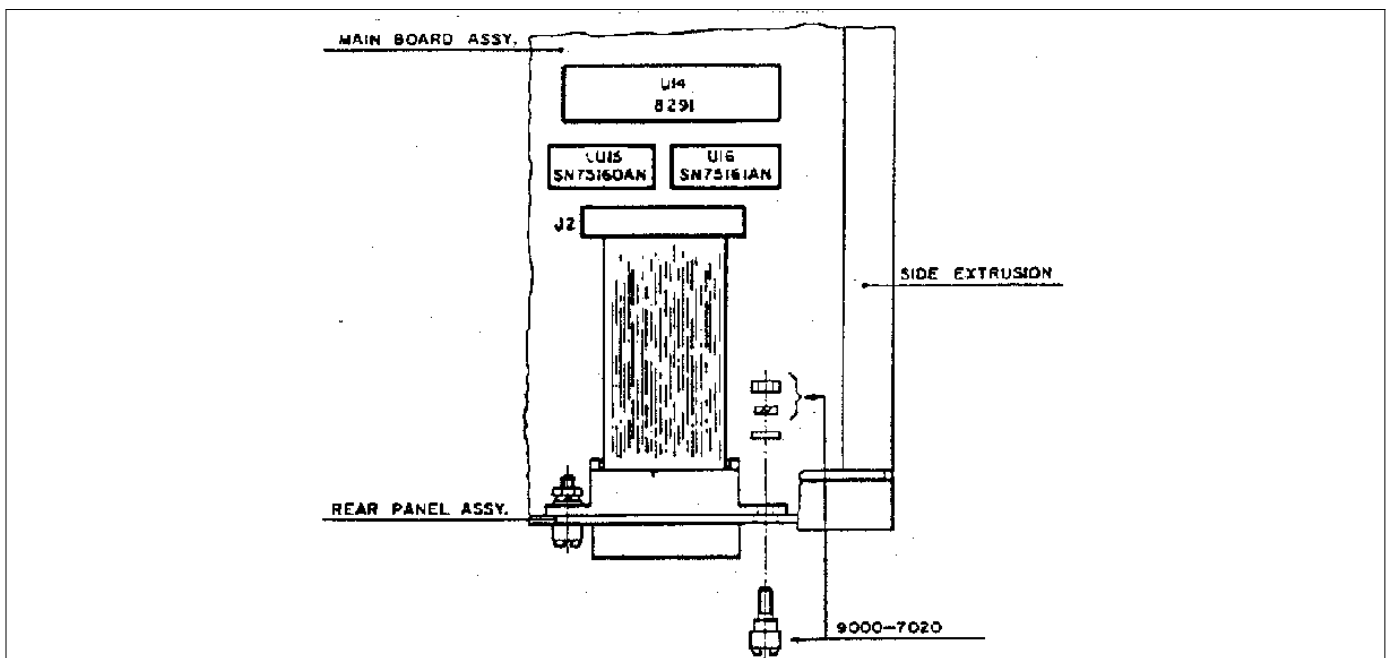

### 5-6. SPECIAL HANDLING OF STATIC SENSITIVE DEVICES

MOS devices are designed to operate at a very high impedance levels for low power consumption. As a result, any normal static charge that builds up on your person or clothing may be sufficient to destroy these devices if they are not handled properly. When handling such devices, use precautions which are described in the following to avoid damaging them.

1. The MOS ICs should be transported and handled only in containers specially designed to prevent static build-up. Typically, these parts will be received in static-protected containers of plastic or foam. Keep these devices in their original containers until ready for installation.
2. Remove the devices from the protective containers only at a properly grounded work station. Also ground yourself with a suitable wrist strap.
3. Remove the devices only by the body; do not touch the pins.
4. Any printed circuit board into which the device is to be inserted must also be grounded to the bench or table.
5. Use only anti-static type solder sucker.
6. Use only grounded soldering irons.
7. Once the device is installed on the PC board, the device is normally adequately protected, and normal handling resume.

### 5-7. CLEANING

Model 8020 should be cleaned as often as operating condition require. Thoroughly clean the inside and the outside of the instrument. Remove dust from inaccessible areas with low pressure compressed air or vacuum cleaner. Use alcohol applied with a cleaning brush to remove accumulation of dirt or grease from connector contacts and component terminals.

Clean the exterior of the instrument and the front panel with a mild detergent mixed with water, applying the solution with a soft, lint-free cloth

### 5-8. REPAIR AND REPLACEMENT

Repair and replacement of electrical and mechanical parts must be accomplished with great care and caution. Printed circuit boards can become warped, cracked or burnt from excessive heat or mechanical stress. The following repair techniques are suggested to avoid inadvertent destruction or degradation of parts and assemblies.

Use ordinary 60/40 solder and 35 to 40 watt pencil type soldering iron on the circuit board. The tip of the iron should be clean and properly tinned for best heat transfer to the solder joint. A higher wattage soldering iron may separate the circuit from the base material. Keep the soldering iron in contact with the PC board for a minimum time to avoid damage to the components or printed conductors.

To desolder components use a commercial "solder sipper", or better, solder removing SOLDER - WICK, size 3. Always replace a component with its exact duplicate as specified in the parts list.

### 5-9. PERFORMANCE CHECKS

The following performance checks verify proper operation of the instrument, and should normally be used:

1. As part of incoming inspection of instrument specifications;
2. As part of troubleshooting procedure;
3. After any repair or adjustment, before returning instrument to regular service.

#### 5-9-1. Environmental Conditions

Tests should be performed under laboratory conditions having an ambient temperature of 25 +/-5 deg C and a relative humidity of less than 80%. If the instrument has been subjected to conditions outside these ranges, allow at least one additional hour for the instrument to stabilize before beginning the adjustment procedure.

#### 5-9-2. Warm-Up Period

Most equipment is subject to at least a small amount of drift when it is first turned on. To ensure accuracy, turn on the power to the Model 8020 and allow it to warm-up for at least 30 minutes before beginning the performance tests procedure.

#### 5-9-3. Recommended Test Equipment

Recommended test equipment for troubleshooting, calibration and performance checking is listed in table 5-2. Test instruments other than those listed may be used only if their specifications equal or exceed the required characteristics.



Table 5-2. Required Test Equipment.

Instrument	Recommended Model	Specifications	Use (*)
Counter	Tabor 6020	200MHz Universal	P,A,T
DMM	Tabor 4121	.1V- 100V,AC rms,DC	P,A,T
Function Generator	Tabor 8200	1mHz - 20MHz	P
Synthesizer	Marconi 2019	80KHz-1040MHz	P,A
Oscilloscope	Tek 465	100MHz band width	P,A,T
Distortion analyser	K-H 6900	100Hz - 1MHz	P,A
Spectrum analyser	HP 182T/8557A	10KHz - 350MHz	P
50 ohm feedthrough Termination	Tek 011-0049-01	50 ohm, 2W, 1%	P,A

(\*) P= Performance Test, A= Adjustments, T= Troubleshooting

**5-10. PERFORMANCE CHECKS PROCEDURE**

**5-10-1. Frequency - Gated Mode**

Accuracy specifications: +/-3 % of full scale up to 1.999 MHz; +/-5 % of full scale up to 20.00 MHz  
 Equipment: Counter

1. Set 8020 as follows:

<u>CONTROL</u>	<u>POSITION</u>
Amplitude	1.50 V
Offset	0.00 V
Trigger Mode	Continuous
Display Modify	FREQ
Operating Mode	VCO
Output	Squarewave

2. Set counter to frequency measurement.  
 3. Set 8020 frequency and verify counter frequency reading as follows:

<u>8020 SETTING</u>	<u>COUNTER READING</u>
2.000 Hz	1.940 Hz - 2.060 Hz
20.00 Hz	19.40 Hz - 20.60 Hz
200.0 Hz	194.0 Hz - 206.0 Hz
2.000 KHz	1.940 KHz - 2.060 KHz
20.00 KHz	19.40 KHz - 20.60 KHz
200.0 KHz	194.0 KHz - 206.0 KHz
2.000 MHz	1.940 MHz - 2.060 MHz
20.00 MHz	19.00 MHz - 21.00 MHz

**5-10-2. Frequency - Continuous Mode**

Accuracy specifications: +/-3 % of full scale up to 9.999 Hz; +/-0.1 % of full scale up to 20.00 MHz (full scale reading is 2000 counts)

Equipment: Counter

1. Set 8020 as follows:

<u>CONTROL</u>	<u>POSITION</u>
Amplitude	1.50 V
Offset	0.00 V
Trigger Mode	Continuous
Display Modify	FREQ
Operating Mode	Normal
Output	Squarewave

2. Set counter to frequency measurement.  
 3. Set 8020 frequency and verify counter frequency reading as follows:

<u>8020 SETTING</u>	<u>COUNTER READING</u>
20.00 Hz	19.98 Hz - 20.02 Hz
200.0 Hz	199.8 Hz - 200.2 Hz
2.000 KHz	1.998 KHz - 2.002 KHz
20.00 KHz	19.98 KHz - 20.02 KHz
200.0 KHz	199.8 KHz - 200.2 KHz
2.000 MHz	1.998 MHz - 2.002 MHz
20.00 MHz	19.98 MHz - 20.02 MHz

**5-10-3. Amplitude**

Accuracy specifications (1KHz): +/-2% of reading from 1.0 V to 15.0 V; +/-4% of reading from 10 mV to 1.50 V

Equipment: DMM

1. Set 8020 as follows:

<u>CONTROL</u>	<u>POSITION</u>
Frequency	1.000 KHz
Amplitude	15.0 V
Offset	0.00 V
Trigger Mode	Continuous
Display Modify	AMPL
Operating Mode	Normal
Output	Squarewave

2. Set DMM to ACV measurements (RMS).

3. Set 8020 amplitude and verify DMM amplitude reading as follows:

<u>8020 SETTING</u>	<u>DMM READING</u>
Square 15.0 V	7.35 V - 7.65 V
Square 1.50 V	.720 V - .780 V
Square 150 mV	72.0 mV - 78.0 mV
Triangle 15.0 V	4.25 V - 4.41 V
Triangle 1.50 V	.415 V - .450 V
Triangle 150 mV	41.5 mV - 45.0 mV
Sine 15.0 V	5.22 V - 5.42 V
Sine 1.50 V	.511 V - .533 V
Sine 150 mV	51.1 mV - 55.3 mV

**5-10-4. DC Characteristics**

Accuracy specifications: +/- (1% of reading + 20 mV) from -7.50 V to +7.50 V; +/- (2% of reading + 2 mV) from -.750V to +.750V

Equipment: DMM

1. Set 8020 as follows:

<u>CONTROL</u>	<u>POSITION</u>
Frequency	X (don't care)
Amplitude	X (don't care)
Function	DC
Trigger Mode	Continuous
Display Modify	AMPL
Operating Mode	Normal

2. Set DMM to DCV measurements.

3. Set 8020 amplitude and verify DMM amplitude reading as follows:

<u>OFFSET SETTING</u>	<u>DMM READING</u>
+/-7.50 V	+/-7.40 V to +/-7.60 V
+/-5.00 V	+/-4.93 V to +/-5.07 V
+/-750 mV	+/- .733 V to +/- .767 V
+/-500 mV	+/- .488 V to +/- .512 V

**5-10-5. Squarewave Characteristics**

Specified transition time: nS (10% to 90% of amplitude)

Specified aberration: 5% of amplitude

Equipment: Oscilloscope

1. Set 8020 as follows:

<u>CONTROL</u>	<u>POSITION</u>
Frequency	1.000 MHz
Amplitude	15.0 V
Offset	0.00 V
Trigger Mode	Continuous
Display Modify	FREQ
Operating Mode	Normal
Output	Squarewave

2. Set oscilloscope and verify as follows:

Rise Time 12 nsec Fall Time 12 nsec Overshoot 5% of amplitude

**5-10-6. Sine Characteristics**

Specified total harmonic distortion: % from 2 mHz to 19.99 Hz; .5% from 20 Hz to 100 KHz % from 100 KHz to 1 MHz

Specified harmonic signals: More than 25 dB below the carrier level from 1 MHz to 20 MHz

Equipment: Distortion Analyzer, Spectrum Analyser

1. Set 8020 as follows:

<u>CONTROL</u>	<u>POSITION</u>
Frequency	10.0Hz
Amplitude	10.0V
Offset	0.00V
Trigger Mode	Continuous
Display Modify	FREQ
Operating Mode	Normal
Output	Sine

2. Set Distortion Analyzer to % Distortion measurements and verify distortion reading as follows:

<u>8020 SETTING</u>	<u>DISTORTION ANALYZER READING</u>
10.00 Hz	1.0 %
100.0 Hz	0.5 %
1.000 KHz	0.5 %
10.00 KHz	0.5 %
100.0 KHz	0.5 %
1.000 MHz	1.0 %

3. Tune Spectrum Analyser for minimum display amplitude and adjust gain so that fundamental corresponds to 0dB.
4. Change 8020 frequency setting to 10 MHz.
5. Verify that all harmonics are less than -25dB
6. Change 8020 frequency setting to 20 MHz.
7. Verify that all harmonics are less than -25dB.

**5-10-7. Sine Flatness**

Level flatness: .5 dB to 2.000 MHz; .5 dB to 20.00 MHz  
 Equipment: Oscilloscope

1. Set 8020 as follows:

<u>CONTROL</u>	<u>POSITION</u>
Frequency	2.000 KHz
Amplitude	15.0 V
Offset	0.00 V
Trigger Mode	Continuous
Display Modify	FREQ
Operating Mode	Normal
Output	Sine

2. Connect 8020 OUTPUT to oscilloscope and set oscilloscope to display waveform within exactly 6 vertical divisions.
3. Change 8020 Frequency setting to 2.000 MHz. Verify that peak to peak of displayed waveform is greater than 5.7 divisions.
4. Change 8020 Frequency setting to 20.00 MHz. Verify that peak to peak of displayed waveform is greater than 5.1 divisions.

**5-10-8. Trigger, Gate, Manual**

Specifications: Each trigger input cycle or manual button press generates a gated output signal or a single output cycle  
 Equipment: 8200 Function Generator, Oscilloscope

1. Set 8020 as follows:

<u>CONTROL</u>	<u>POSITION</u>
Frequency	20.00 KHz
Amplitude	15.0 V
Offset	0.00 V
Trigger Mode	Gated
Display Modify	FREQ
Operating Mode	Normal
Output	Sine

2. Set external 8200 function generator to 1 KHz and 4 V positive pulse. Connect external 8200 function generator to TRIG IN BNC. Check on oscilloscope for 8020 output signal.
3. Disconnect external function generator and press the MANUAL push- button. Check on oscilloscope for signal present at 8020 output as long as MANUAL button is depressed.
4. Change 8020 setting to Triggered mode.
5. Reconnect external function generator to 8020 TRIG IN terminal.
6. Check on oscilloscope for 8020 output signal. A single waveshape is generated on every rising edge of the triggering signal.
7. Change 8020 setting to 10Hz.
8. Disconnect external function generator and press the MANUAL button. check on oscilloscope for a single pulse after each time the MANUAL button was depressed. Use TTL output of external function generator to trigger oscilloscope externally whenever necessary.

**5-10-9. Sweep**

Specifications: Logarithmic 10 decades, Linear 3 deades, Automatic up or down, Gated and Triggered sweep  
 Equipment: Oscilloscope, Counter

1. Set 8020 as follows:

<u>CONTROL</u>	<u>POSITION</u>
Frequency	20.00 KHz
Amplitude	15.0 V
Offset	0.00 V
Trigger Mode	Continuous
Sweep stop	2.00 KHz
Sweep time	1 Sec
Sweep marker	10.00 KHz
Display Modify	TIME
Operating Mode	Sweep On
Sweep Type	Logarithmic Down
Output	Sine

2. Connect Output terminal to oscilloscope and Set oscilloscope so that sweep may be observed. Note that 8020 sweeps down.
3. Change 8020 Sweep Time setting throughout the range and observe that sweep time changes accordingly.
4. Change Sweep type setting to UP and observe that 8020 sweeps up.
5. Connect Sweep Out terminal on the rear panel to the oscilloscope and observe that DC level changes 2V for a full sweep cycle.
6. Connect Marker out to the oscilloscope and observe that output changes from 0V to -5V when marker frequency is reached
7. Change Trigger Mode to Gated
8. Connect an external gating signal to the TRIG IN terminal. Observe that the 8020 sweeps as long as the gating signal remains high
9. Change 8020 Trigger Mode to Sweep and Triggered and observe that the 8020 sweeps once for every rising edge of the triggering signal

**NOTE**

It is also possible to check the sweep in the different trigger modes using the MANUAL button where as long as it is depressed serves as gating signal in gated mode and as trigger in triggered mode.

**5-10-10. VCO Control**

Control amplitude: 0 V to 10 V DC +/-20 %.  
 VCO control range: 1000:1 change from frequency setting at 2000 counts

Equipment: Power Supply, DMM, Counter

1. Set 8020 as follows:

<u>CONTROL</u>	<u>POSITION</u>
Frequency	2.000 MHz
Amplitude	1.50 V
Offset	0.00 V
Trigger Mode	Continuous
Display Modify	FREQ
Output	Squarewave
Operating Mode	VCO On

2. Apply power supply output to VCO IN connector and slowly increase power supply amplitude from 0V to 10 V +/-20% DC. Verify with counter that output frequency changes from 2.000 MHz to about 2 KHz.

**NOTE**

Performance verification of VCO operation should be carried out with a very clean DC voltage. A noisy Power supply output will cause phase modulation in the 8020 output.

**5-10-11. Pulse Width (model 8021)**

Accuracy Specifications: +/- (3 % + 4 nSec) from 25 nS to 99.9 mS; +/- 10% from 100 mS to 9.99 S

Equipment: Counter, Oscilloscope, 50 ohm Feed-through Termination, BNC Cable

1. Set 8021 as follows:

<u>CONTROL</u>	<u>POSITION</u>
Amplitude	1.50 V
Offset	0.00 V
Trigger Mode	Continuous
Display Modify	WID
Operating Mode	Pulse
Output	Squarewave

2. Set counter to pulse width measurement.
3. Connect 8021 to Channel A of the counter. Set 8021 Pulse Width and Frequency and verify counter reading as follows:

<u>FREQ SETTING</u>	<u>WIDTH SETTING</u>	<u>COUNTER READING</u>
2.000E 6	99.9E-9	100 nS +/-7 nS
500E 3	500E-9	500 nS +/-19 nS
50.0E 3	5.00E-6	5.00 uS +/- .15 uS
5.00E 3	50.0E-6	50.0 uSec +/-1.5 uS
500E 0	500E-6	500 uS +/-15 uS
50.0E 0	5.00E-3	5.00 mS +/- .15 mS
5.00E 0	50.0E-3	50.0 mS +/-1.5 mS
1.00E 0	500E-3	500 mS +/-50 mS
100E-3	5.00E 0	5.00 S +/-500 mS

The following ranges are to be checked using an oscilloscope.

4. Connect 8201 OUTPUT to the oscilloscope input and verify measurements as follows:

<u>FREQ SETTING</u>	<u>WIDTH SETTING</u>	<u>OSCILLOSCOPE READING</u>
10.00 E 6	25.0 E-9	25 nS +/-4 nS

**5-10-12. Amplitude Modulation (model 8022)**

Sensitivity Specifications: 2.5 Vp-p produces 100 % modulation depth when carrier is set to 100 %.

AM Distortion: 1 % at 70 % AM with 1 KHz envelope and 1 MHz carrier.

AM Envelope Bandwidth: DC to 500 KHz.

Equipment: Function generator, Oscilloscope, Distortion Meter, De- modulator

1. Set 8022 as follows:

<u>CONTROL</u>	<u>POSITION</u>
Frequency	1.000MHz
Amplitude	15.0V
Offset	0.00V
Trigger Mode	Continuous
Display Modify	CARR
Output	Sine
Operating Mode	AM

2. Connect 8022 output to oscilloscope input. Adjust oscilloscope vertical gain so that trace height is +/-2 vertical divisions.

3. Set external function generator to output 1 KHz sine waveform and connect external function generator to AM IN connector.

4. Adjust amplitude of external generator until oscilloscope displays 100 % modulation. Remove external generator from AM input and verify that external generator amplitude is 2.5 Vp-p +/-0.25 V.

5. Change external function generator to 1 KHz sine waveform and 1.2 Vp-p amplitude. Connect external generator to 8022 AM IN connector.

6. Change external generator frequency setting from 1 KHz to 500 KHz and 8022 frequency setting to 10.00MHz. Verify that 8022 output did not decrease by more than 30 %.

7. Change 8022 frequency setting to 1 MHz. Change external function generator settings to 1 KHz sine waveform and 1.7 Vp-p amplitude. Connect external generator to 8022 AM IN connector.

8. Connect 8022 output through the AM de-modulator to the distortion analyzer. Verify that distortion is less than 1 %.

## SECTION 6

### THEORY OF OPERATION

#### 6-1. INTRODUCTION

This section contains an overall functional description of the 8020 series function generators as well as detailed circuit analysis of the various sections of the instruments. Information pertaining to the pulse width, the amplitude modulation and the standard IEEE interface (Option 1) are also included.

Information is arranged to provide a description of individual functional circuit blocks. As an aid to understanding, the descriptions are keyed to accompanying block diagrams and simplified schematics. Detailed schematics and component layout drawings are located at the end of this instruction manual.

#### 6-2. OVERALL FUNCTIONAL DESCRIPTION

The 8020 series is a line of fully programmable function generators having various standard output functions. All parameters are adjustable through front panel touch switches or through IEEE programming. The high performance of the 8020 series is accomplished by utilizing a very fast, discrete analog circuits. Microprocessor and digital circuits control the performance of the analog circuits and permit direct interfacing to the front panel keyboard and display and to the optional IEEE-488 GPIB; option 1.

A simplified block diagram of the instrument is shown in Figure 6-1. The heart of the function generator is its VCO, where two identical currents with opposite polarities are created. These two currents are switched in, on and off, charging and consequently discharging a capacitor. This cycle generates a continuous reclining and declining voltage ramps. The repetition rate depends on the applied capacitor and the supplied current.

The same ramp is used for driving the triangle and the squarewave buffers. The triangle waveform is also utilized in generating the sinewave output by using a sine shaper. The three basic waveforms are then amplified or

attenuated through the output amplifier and fed to the OUTPUT connector. The output amplifier is capable of driving its waveforms into a 50 load.

External gating or triggering effect the current which is supplied to the current generator.

The analog signals are controlled by D to A converters. The D to A converters receive their controlling information through serial to parallel converters; directed by the microprocessor components.

#### 6-3. ANALOG CIRCUITRY

The following paragraphs contain descriptions of the current generator the VCO (voltage controlled oscillator) the sine shaper the trigger circuit the final amplifier and the attenuators. Complete and detailed schematics are located at the end of this manual.

##### 6-3-1. Current Generator

The current generator generates the necessary currents for the VCO and the trigger circuits. Figure 6-2 is a simplified diagram of the current generator. The current generator is composed of the following sections: Reference source, DAC, Up/Down current sources, and trigger current source. Each one is discussed in detail below.

**REFERENCE SOURCE** - The reference source generates the voltage for the DAC. The reference comprises a zener diode CR13, operational amplifier U33 and their associated components. When used as a voltage controlled oscillator, an external voltage is applied to the VCO input terminal through U48 and U49. This voltage is then fed through U33 to the current generator.

**DAC** - The DAC (digital to analog converter) includes U34 and operational amplifier U28. Shift registers U29 and U30 control the digital information for the data inputs

of U34. The reference for the DAC is provided from the output of the reference source.

**UP/DOWN CURRENT SOURCES** - The output from the DAC from U34 is voltage shifted by Q10 and applied to a voltage mirror U27 and Q9. The emitter of Q9 drives the up current source while the collector, through CR8 drives the down current source. The up current source is

formed by U25, Q6 and their associated components. The down current source is formed by U26, Q7 and their associated components.

**TRIGGER CURRENT SOURCE** - The same precision-current generator, which supplies the down current source, supplies the current to the trigger current source. The trigger current source is doubled and compared with

Figure 6-1. Model 8020 - Simplified Block Diagram

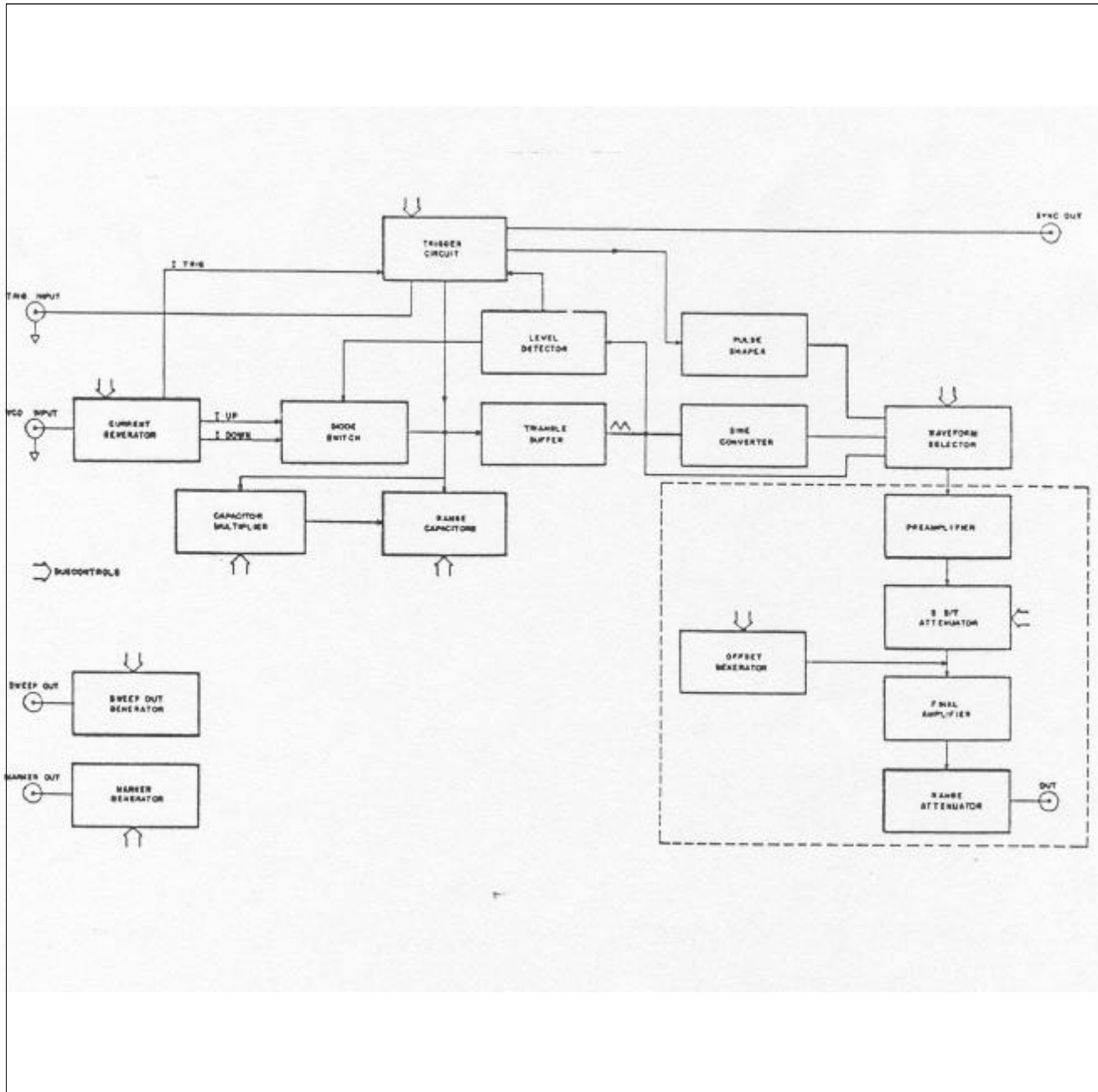

the down current source. The trigger current source is comprised of the Q8 and R19.

### 6-3-2. Voltage Controlled Oscillator

Figure 6-3 is a simplified block diagram of the VCO sec-

Figure 6-2. Current Generator Simplified Block Diagram

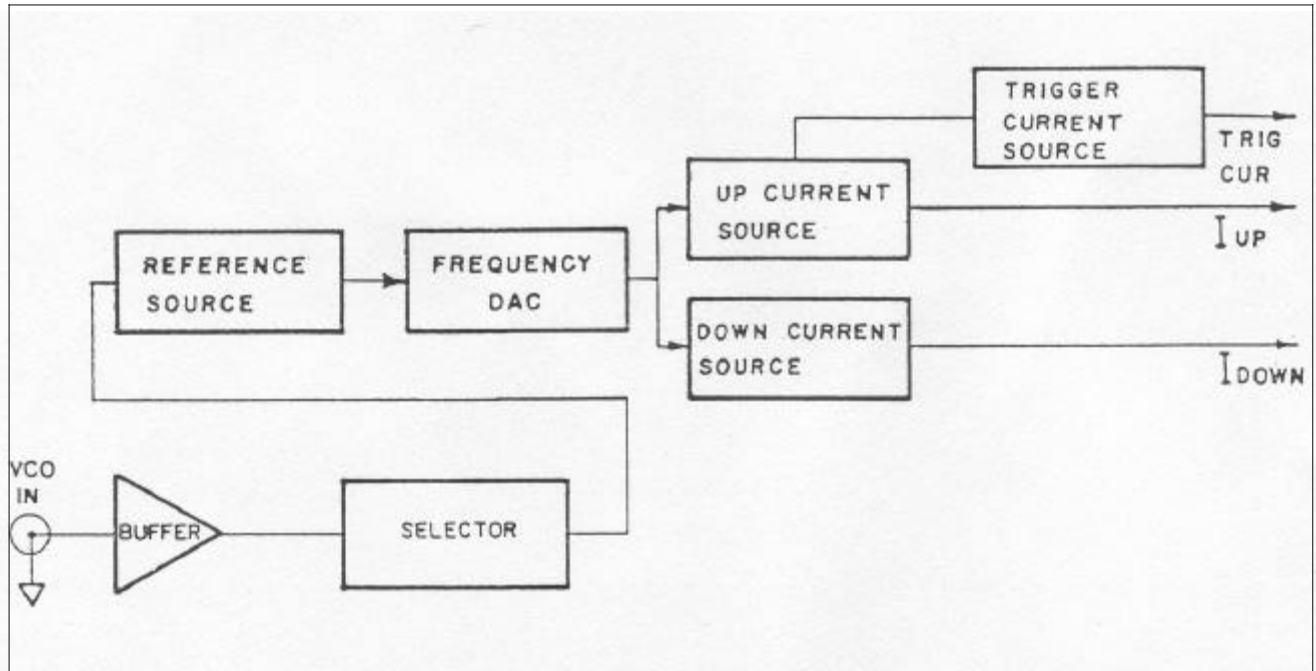

tion. Refer to this Figure throughout the following descriptions. Assuming that the diode bridge switch is operating in such a way that  $I_{up}$  is flowing to the range capacitor, the capacitor is charged with this current which creates a positive going voltage ramp. This voltage ramp is fed through an impedance converter to the triangle buffer. This buffer isolates the capacitors from the level detector and provides sufficient voltage amplitude for the level detector. When the voltage ramp reaches a predetermined threshold level, the level detector operates the diode switch so that the current now flows through the  $I_{down}$  source. This causes the same reaction as described above but with opposite direction. The following paragraphs describe the voltage controlled oscillator in depth.

**DIODE SWITCH** - The diode switch consists on the following parts: CR19, CR20, CR17, CR18, CR21 and CR22. The up current is supplied through R67 and the down current is supplied through R68. CR17 and CR19 as well as CR18 and CR20 are connected in series to reduce

the feedthrough from the switch drive signal to the range capacitors.

**TRIANGLE BUFFER** - The triangle buffer includes impedance converter FET Q19, transistors Q22, 23, 24 and Q25 and their associated components.

**LEVEL DETECTOR** - The level detector consists of U43 and Q27 through Q30. The positive threshold is set by R101 and R107 and the negative threshold is set by R104 and R106. The rectangular signals which are then used to switch the diode switch are taken from Q27 and Q30. Q26 with CR23, CR24 and CR25 translate the rectangular waveform from the collector of Q28 to a TTL level signal which is then sent to the trigger circuitry.

**RANGE CAPACITORS** - The frequency at the main output is being generated by charging capacitors which also create the triangle waveform. The range capacitors C38 through C46 are used for the 20Hz to 20MHz ranges. U38 receives the serial data from the digital circuit, converts the serial data to parallel information which is fed to the quad comparator U39. The outputs of the quad comparator are then fed to the bases Q15 through Q18 which in turn select the correct range capacitor.



Figure 6-3. VCO Simplified Block Diagram.

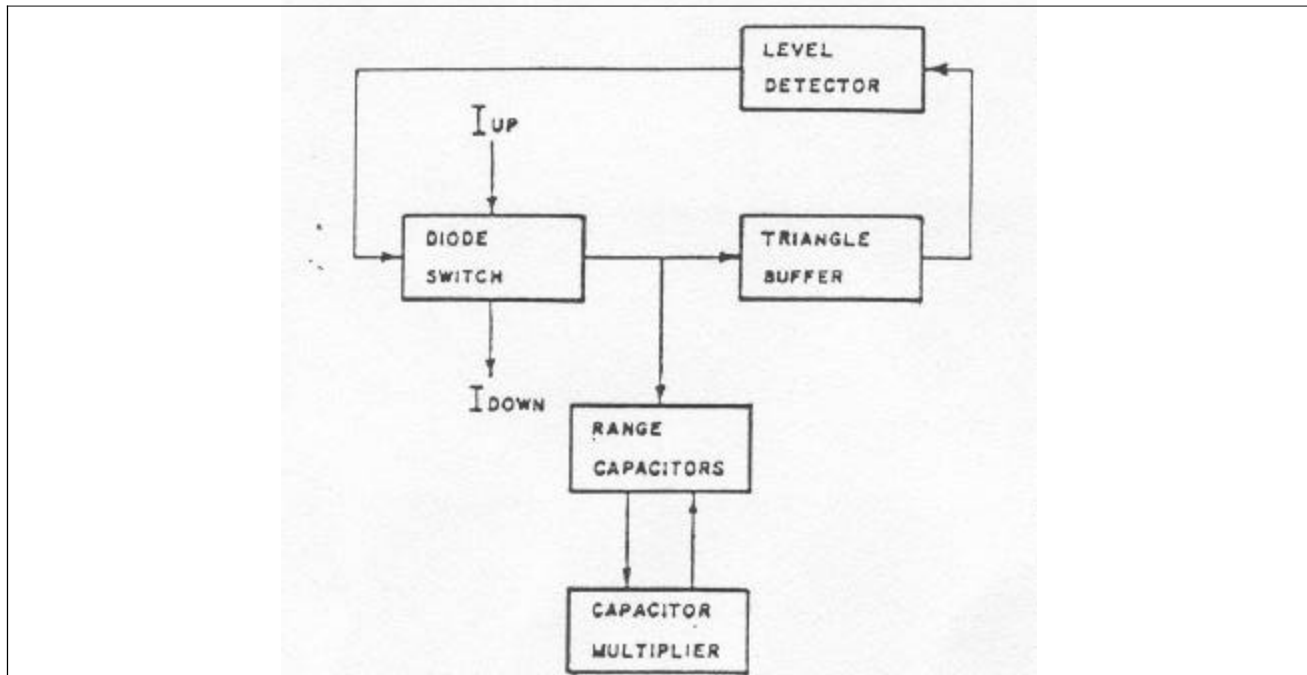

**CAPACITOR MULTIPLIER** - The capacitor multiplier is used for the 2mHz to 19.9Hz ranges. The function of this circuit is to generate an equivalent large capacitance. The larger values of capacitors are required to generate lower frequencies. The capacitor multiplier is formed by U40, U41 and their associated components. The multiplier ratio is selected by changing the ranging resistors in the negative feedback path of U40. The ranging resistors are selected by Q43 and analog switch U42. The switching control is provided by the serial to parallel converter U38.

### 6-3-3. Sine Shaper

The sine shaper consists of a series of differential stages which are formed by the transistor arrays U45, U46 and U47. The differential stages are connected in parallel and receive the drive signal from the triangle buffer output. This circuit takes advantage of the non-linear characteristics of the transistors and by biasing them to different dc levels, the output of the common collector is shaped to a sine wave. The sine wave is then amplified and re-biased to oscillate around 0V with a differential amplifier which is formed by Q34, Q35, Q36 and Q37, U45b, U45c and their associated components.

### 6-3-4. Trigger Circuit

The trigger circuit is active when one of the trigger modes is selected. The trigger circuit is composed of two main sections: the clamp circuit and the trigger logic circuit. Figure 6-4 is a simplified block diagram of the clamp circuit. Refer to this Figure and to the schematic diagrams at the end of this manual throughout the following description. Detailed description of the clamp and the trigger logic circuits is provided in the following. Description is given for both trigger and gated modes.

**CLAMP CIRCUIT** - The clamp circuit is composed of U24, Q20, Q21 and their associated components. When no trigger mode is selected, U24 is cleared with its inverted Q output set to "1". At this time, the trigger current flows through Q20. Q21, which is connected as a diode, is reversed biased and do not interfere with normal VCO operation.

Selecting one of trigger or gated modes its inverted Q output is modified to "0". The up current from the VCO circuit is diverted through Q21 to the junction of Q20 and Q21. Due to the fact that the Current from the trigger current is double that of the up or down currents, the current flow through Q20 will equal to that flowing through Q21. Under these conditions, the clamp level, at the triangle buffer input will be set to logical "0" level. This sequence

clamps the input of the triangle buffer to a level which is set by the clamp voltage generator.  
 Figure 6-5 shows the waveforms of the clamp circuit in triggered operating mode and Figure 6-6 shows the waveforms of the clamp circuit in gated operating mode.

**TRIGGER LOGIC** - The trigger logic is formed by U22 and U24. The triggering signal is routed through R12 to the input of U22A. Selecting continuous mode sets the control inputs of U22b and U22c to "0". This sets U24 to "0" level and keeps Q21 off. This action blocks any signals coming from the trigger input.

Figure 6-4. Model 8020 Clamp Circuit Simplified Diagram

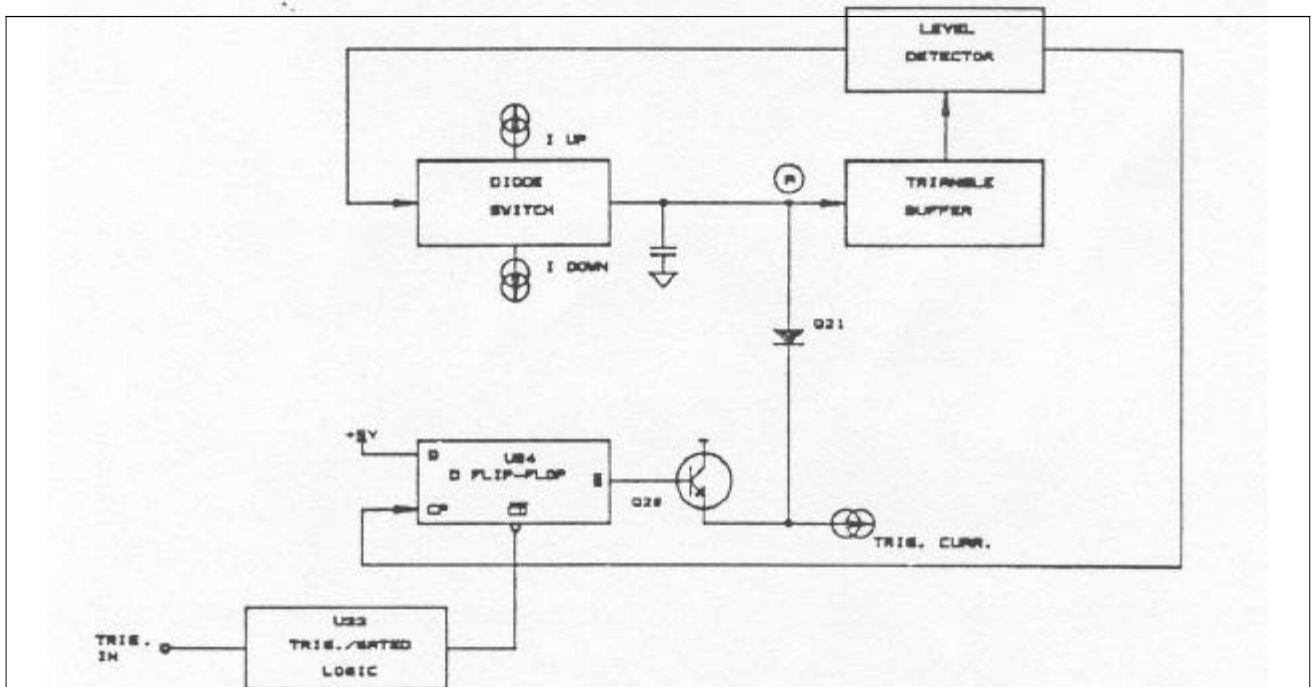

Figure 6-5. Model 8020 Clamp Circuit Waveforms (Triggered Mode)

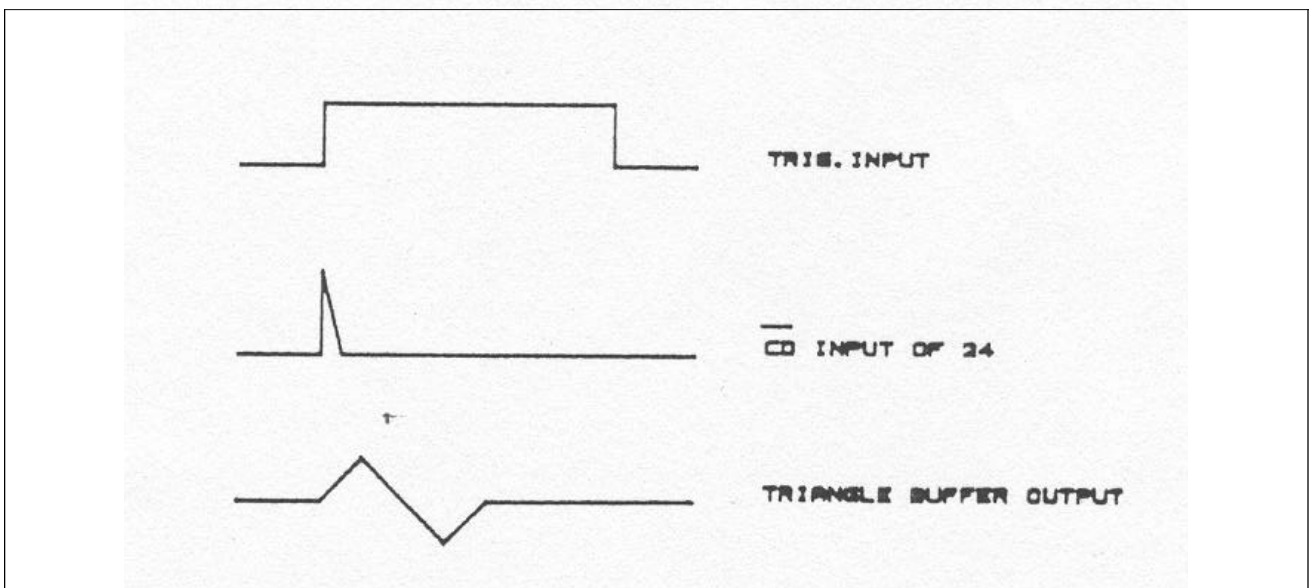
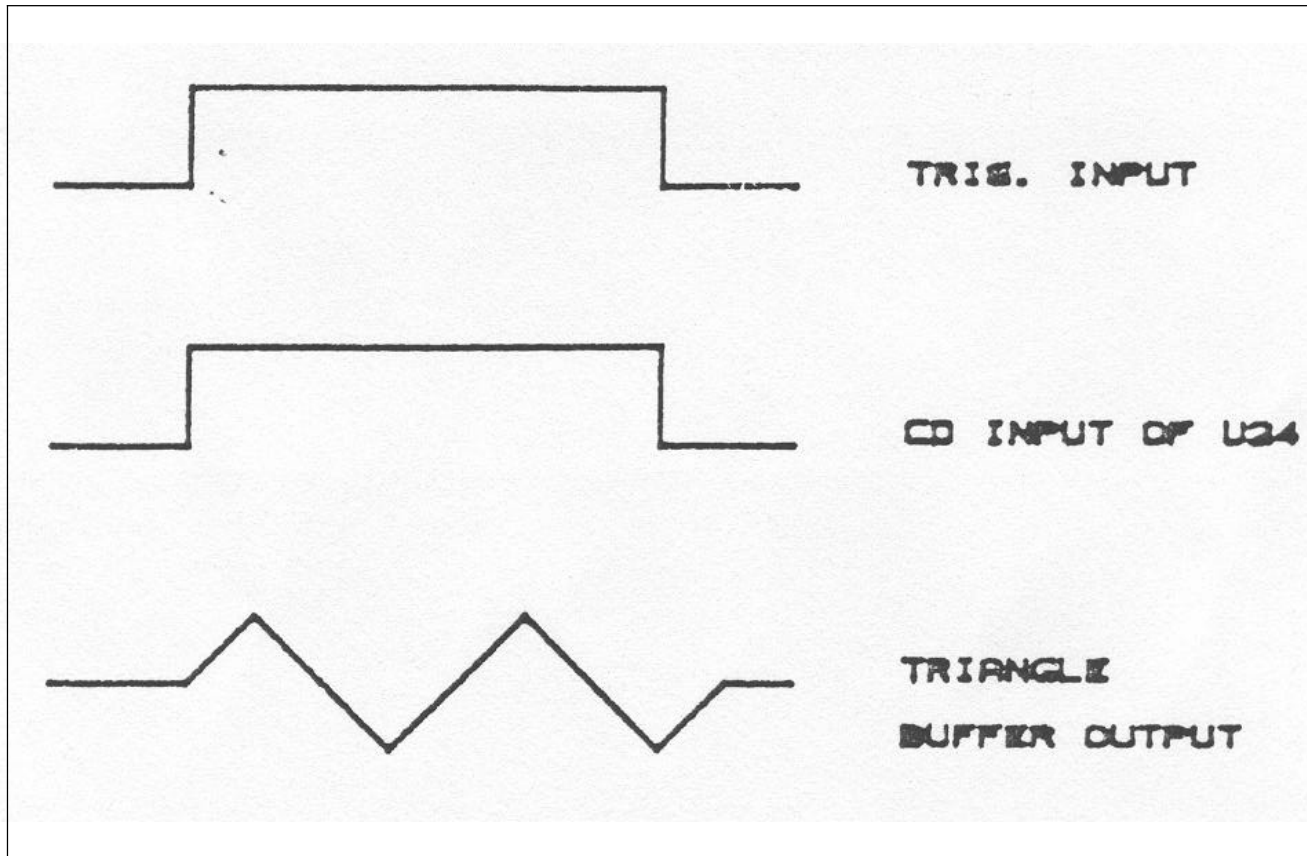

Figure 6-6. Model 8020 Clamp Circuit Waveforms (Gated Mode)



When the generator is set to operate in Gated mode the gating signal is routed through U22 to U24. The VCO is enabled when the gating signal is high and disabled when the gating signal is low.

Selecting triggered mode, sets the controlling input to U22B to high and the controlling input to U22C to low. A positive transition from the trigger input generates a narrow negative going pulse at U24. This sequence in turn enables one cycle at the VCO output.

### 6-3-5. Pulse Shaper

The purpose of the pulse shaper is to convert the signal from the level detector to pulses having very fast rise and fall times and with precise amplitude. The pulse shaper is located on the output amplifier assembly board. Refer to the schematics at the end of this manual throughout the following description.

The pulse from the VCO is routed via U1 to the pulse shaper. The pulse shaper consists of Q1, Q2, Q3 and Q4,

positive current generator Q10 and negative current generator Q9. When the generator is set to operate in square-wave function, the output of the pulse shaper, alternates between the positive current source and the negative current source. When in positive pulse function, the output alternates between the positive current source and ground and when in negative pulse function, the output alternates between the negative current source and ground. The positive current source consists of U3, Q10 and their associated components. R127 adjusts the positive current. Q7 controls Q8 when positive pulse is selected. The negative Current source consists of U2, Q9 and their associated components. R126 adjusts the negative current amplitude. Q5 controls Q6 when negative pulse is selected.

### 6-3-6. Preamplifier

The pre-amplifier is located on the output amplifier assembly board. Refer to the schematics at the end of this manual throughout the following description. The pre-amplifier consists of U11, Q12, Q13, Q14, Q15 and Q16 and their associated components. U8 is a serial to parallel con-

verter which operates the quad comparator U9 which in turn operates signal selector U10. U10 selects one of the following signals: triangle, sine wave or pulses from the pulse shaper. The signal from the selector is fed in parallel to a low frequency amplifier U11 and its associated components and through C17 and C18 to the high frequency amplifier. The output of the preamplifier, at the junction of R46 and R47 is then routed to the attenuator. Q12 is a -10 dB gain switch which connects R54 in parallel to the feedback resistor R56.

### 6-3-7. Attenuator

The attenuator is located on the output amplifier assembly board. Refer to the schematics at the end of this manual throughout the following description. The attenuator is controlled by 3 quad comparators U5, U6 and U7. The data which is required to operate the comparators is converted from serial to parallel by U4. The attenuator is connected in a binary fashion and comprises FETs Q17 through Q32. One or more switches are on at a time which in turn changes the equivalent resistance from the preamplifier to the power amplifier. This adjusts the amplitude level to the correct level for the output power amplifier.

### 6-3-8. Offset Generator

The offset generator is located on the output amplifier assembly board. Refer to the schematics at the end of this manual throughout the following description. The offset generator generates a DC voltage which is summed with the selected waveform. The DC voltage is generated by the D/A converter U14 and operational amplifiers U15 and U16. The reference voltage level is generated by CR21 and is adjusted by R99. The D to A converter is controlled by serial to parallel converter U13. U17 is connected as a comparator which, when commanded from U19, turns FET switch Q35 on or off; changing the polarity of the DC offset. The DC offset amplitude is coupled through R79 to the output power amplifier.

### 6-3-9. Power Amplifier

Refer to the schematics at the end of this manual throughout the following description. The output amplifier consists of low frequency amplifier U18, high frequency amplifier Q33, Q34 and Q39 through Q46 and class B power stage Q38 through Q43. The signal is coupled to the low frequency amplifier through R95 and to the high frequency amplifier through C36 and C42. The output from the power amplifier at the junction of R117 and R118 is

connected through a 50 ohm resistance to the decade attenuator.

### 6-3-10. Post Amplifier Attenuator

The post amplifier attenuator is the final stage through which the signal is fed. Attenuation ranges from 0dB to 30dB. U19 receives serial information from the microprocessor serial bus, converts the serial information to parallel and operates relays K1, K2 and K3 through buffer U20. The relays select one of the divider networks which are formed by the resistors R120 through R125. Relay K3 disconnects the output signal from the output terminal when a disable command is given through the IEEE bus.

### 6-3-11. Power Supply

Refer to the power supply schematic at the end of this manual for the following discussions. The power supply consists of a main power transformer, three bridge rectifiers, four regulators and a 5V regulator which is formed by U21, Q3, Q4 and Q5, and their associated components. The LINE fuse and the Line Selector are accessible at the rear panel. The LINE VOLTAGE SELECT switch select 115V or 230V operation. CR2 is used as a full-wave rectifier to provide a sufficient DC voltage for the -24V and +24V regulators U17 and U18 respectively. CR1 is used as a full-wave rectifier to provide a sufficient DC voltage for the -15V and +15V regulators U19 and U20 respectively. U21 receives a reference voltage of 5V from the 15V supply. This reference is compared with the 5V supply. The difference is amplified by U21 and Q5 and applied to the series regulator Q3 which, in turn, corrects the output voltage to equal that of the reference voltage.

## 6-4. PULSE GENERATOR CIRCUIT (model 8021)

The pulse generator circuit is constructed on the same board as the output amplifier. The complete assembly, which includes the above sections plus the pulse generator circuit, is unique to the model 8021. In the following, only the section pertaining to the pulse generator is described. The rest of the circuits are identical to those available on the model 8020. Figure 6-8 is a functional block diagram. For complete and detailed schematics, refer to the back of this manual.

In general, the heart of the pulse generator circuit is the switching transistor. This transistor when turned off or on enables a charge or discharge sequence respectively on the range capacitor. The charge current and the selected capacitor determine the width of the pulse.

The sequence is initiated from a steady state condition where the switching transistor is on. At that time the current generator, the range capacitor and the comparator input are shorted to ground. The output from the comparator is set to "1". A positive transition from the VCO circuit modifies the state of the flip-flop turning the transistor off. The current from the current generator is allowed to flow to the range capacitor. The capacitor is charged to a level equal to the reference voltage. At that time the comparator flips its output state to "0", forcing this sequence to an end. The following describes the various sections of the pulse generator in details.

**CURRENT GENERATOR** - The current generator is composed of D/A converter U36, Serial to parallel converter U37 and voltage reference CR41. The CPU generates serial data which is converted to parallel information by U37. CR41 generates a precise voltage which controls the accuracy of the current generator. The current generator is made of an operational amplifiers U33 and U35, and transistors Q67 through Q70. The current is supplied to the selected capacitor through the collector of Q67.

**RANGE CAPACITORS** - Serial data from the CPU is converted to parallel information by U30 and U38. The parallel information, through switching transistors Q62, Q64, Q65, Q60, Q61 Q75 and Q76, is then used for selecting the appropriate capacitor from one of C79 through C86 and C106 respectively.

**COMPARATOR** - The comparator circuit consists of a FET buffer Q66, a monolithic comparator U34 and their associated components. The reference voltage is generated from the +15V supply by the resistor divider R193 and R196.

**SELECTOR** - The selector circuit U31 selects one of the pulse, pulse complement or square waveforms. One of these waveforms are then fed to the pulse shaper.

**RAMP AMPLIFIER** - The ramp amplifier is comprised of operational amplifiers U39 and U40. U41 controls FET switches Q73 and Q74. These switches select ramp polarity.

Figure 6-7. Pulse Generator Functional Block Diagram.

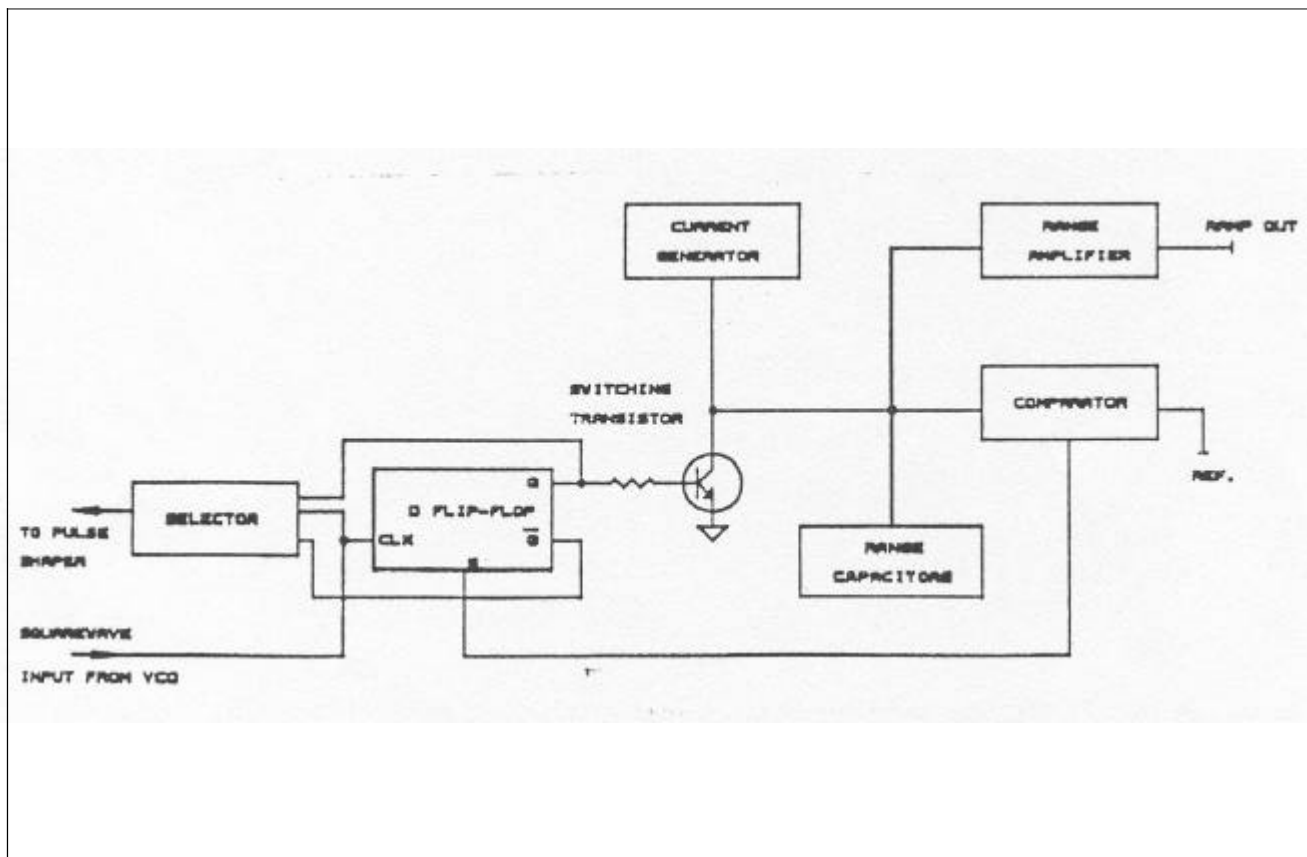

**6-5. AM CIRCUIT (model 8022)**

The AM circuit is constructed on the same board as the output amplifier. The complete assembly, which includes the above sections plus the AM circuit, is unique to the model 8022. In the following, only the section pertaining to the amplitude modulation circuit is described. The rest of the circuits are identical to those available on the model 8020. Figure 6-9 is a functional block diagram. For complete and detailed schematics, refer to the back of this manual.

The modulator is composed of transistor arrays U24 and U25, transistors Q47, Q48 and Q56 and their associated components. The carrier is applied to the base of Q47. The modulating signal is applied through R130, U25, R131 and R174 to the modulator circuit. Carrier level is controlled by U21. U21 receives serial data from the CPU and converts this data to parallel information for driving U22.

**AM AMPLIFIER** - The AM amplifier is a differential amplifier consisting of transistors Q49 through Q54 and their associated components. The output, at the junction of R163 and R167 is fed through a relay K4 to the pre-amplifier circuit.

**6-6. DIGITAL CIRCUITRY**

Model 8020 operation is supervised by the internal microprocessor (CPU). The CPU controls parameter selection process, front panel switching, the displayed read-out and IEEE operation. All of these tasks are performed under software supervision. This section briefly describes the operation of the various sections of the microprocessor and its associated digital circuitry. A simplified block diagram is included for user reference. For more complete circuit details refer to the digital schematics at the end of this manual.

Circuit operation centers around the microprocessor unit (CPU) U5. The CPU is an 8-bit microprocessor capable of directly addressing up to 64K bytes of program memory (ROM) and up to another 64K bytes of data memory (RAM). The microprocessor works with a 10 Mhz clock which is divided by U6 to provide clocks for the various sections of the instrument. Software for the CPU is contained in one EPROM U8 containing 32K bytes of memory space. Temporary storage is provided by RAM U9 which can store up to 2K bytes of information.

**6-6-1. Display And Keyboard Interface**

Interfacing between the CPU, the keyboard and the display is performed by the Keyboard/Display interface U2. The information for the seven segment LEDs is sent through buffer U1 and limiting resistors RN1. U1 multiplex the digits and LED and drive the high current transis-

Figure 6-8. AM Circuit Functional Block Diagram.

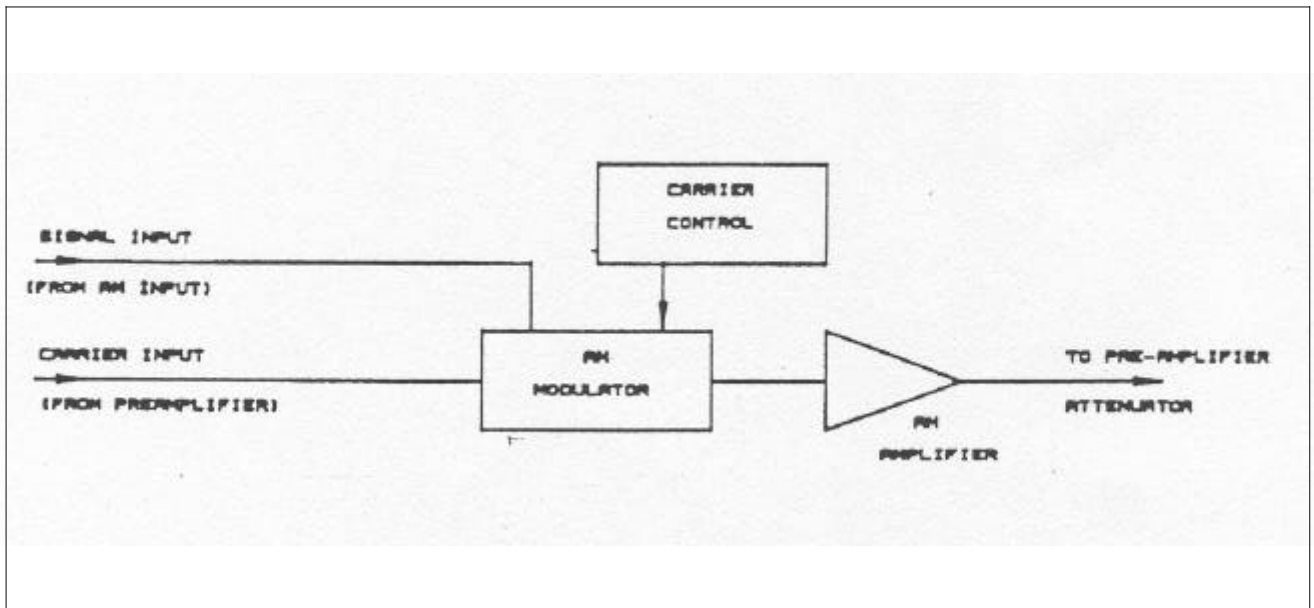

tors Q1 through Q8 which, in turn, drive the anodes of the appropriate LED. The sense lines S0, S1 and S2 determine which of the button were depressed.

#### **6-6-2. Counter Circuit**

The counter circuit is employed in the model 8020 for the purpose of controlling the accuracy of the frequency at the output connector. The counter circuit is composed of divider U10, selector U11, D flip-flop U12 and selector U13. The counter circuit counts the number of pulses from the VCO. The CPU then computes the relation between these pulses to the reference clock. The result is compared to the required accuracy. If deviation is sensed, the CPU sends correcting data to the current generator circuit.

#### **6-6-3. IEEE-488 Interface (option 1)**

The instrument has a built in IEEE-488 interface that permits remote control through a system controller.

The IEEE interface is made up of U11, (General Purpose Interface Adapter), U15 and U16 interface bus drivers. On the CPU side of the GPIB, data transmission is handled much like any other bus transaction. The output of the U14 is standard IEEE format and is buffered by the two IEEE bus drivers U15 and U16. The bus drivers are necessary for enhancing the drive capability of the interface. Up to 15 devices may be connected in parallel.

## SECTION 7

### ADJUSTMENTS

#### 7-1. INTRODUCTION

This section contains information necessary to adjust the 8020 series, the pulse generator circuit (model 8021) and the amplitude modulation circuit (model 8022).

#### **WARNING**

The procedures described in this section are for use only by qualified service personnel. Do not perform these procedures unless qualified to do so. Many of the steps covered in this section may expose the individual to potentially lethal voltages that could result in personal injury or death if normal safety precautions are not observed.

#### 7-2. ADJUSTMENTS

##### 7-2-1. Environmental Conditions

Adjustments should be performed under laboratory conditions having an ambient temperature of 24 +/-5 degC and a relative humidity of less than 70%. If the instrument has been subjected to conditions outside these ranges, allow at least one additional hour for the instrument to stabilize before beginning the adjustment procedure.

##### 7-2-2. Warm-Up Period

Most equipment is subject to at least a small amount of drift when it is first turned on. To ensure long-term calibration accuracy, turn on the power to the Model 8020 and allow it to warm-up for at least 20 minutes before beginning the adjustment procedure.

##### 7-2-3. Recommended Test Equipment

Recommended test equipment for calibration is listed in Table 5-3. Test instruments other than those listed may be used only if their specifications equal or exceed the required characteristics.

#### 7-2-4. Adjustment Procedures

All adjustments are performed with the POWER switch ON. The top cover should be removed to allow access to test points and adjustments. Between adjustments, always leave top cover on the unit to keep internal temperature.

#### **WARNING**

Take special care to prevent contact with live circuits or power line area which could cause electrical shock resulting in serious injury or death. Use an isolated tool when making adjustments. Use plastic or nylon screw-driver when adjusting the time base trimmer as other material will cause confusion in this adjustment.

Refer to the component layout in Section 9 when necessary for determining adjustment points. Follow the procedure in the sequence indicated because some of the adjustments are interrelated and dependent on the preceding steps.

Verify that Model 8020 is functioning according to the performance checks. Make sure that all results are within, or close to, the range of the required specifications, otherwise refer to the troubleshooting procedures given later in this section.

Center all trimmers and if necessary, remove selected components and clear the holes to allow a selection of new components.

Perform the following adjustment procedure. If an adjustment can not be made to obtain a specific result, refer to the troubleshooting procedures.

#### **NOTE**

If not otherwise specified, set Model 8020 controls as follows and terminate the OUTPUT with a 50 ohms feedthrough termination.



<u>CONTROL</u>	<u>POSITION</u>
Frequency	As required by procedure
Amplitude	1.00 V
Offset	0.00 V
Sweep Stop	2.0 MHz
Sweep Time	1 S
Sweep Marker	10 MHz
Operating Mode	Normal (all lights off)
Trigger Mode	Continuous (all lights off)
Output	Squarewave

### 7-3. ADJUSTMENT PROCEDURE

#### 7-3-1. Power Supply Adjustment

Equipment: DMM

1. Set DMM to DC measurements. Measure and record the -15 V supply voltage with 10 mV resolution.
2. Adjust R172 so that the +15 V supply would be the same as the voltage level recorded in step 1.

#### 7-3-2. Distortion Adjustment

Equipment: Distortion Analyzer, Oscilloscope

1. Change 8020 Output setting to Sine.
2. Change 8020 Frequency setting to 2.000 KHz.
3. Set the oscilloscope to 1V/Div. and DC coupling and adjust the trace line vertically to be exactly at the center of the screen (0 V).
4. Connect the OUTPUT terminal to the oscilloscope and adjust R172 to get a symmetrical waveform, about the 0V line, on the screen.
5. Disconnect the OUTPUT from the oscilloscope and connect the OUTPUT to the distortion analyzer.
6. Adjust R115 and R129, repeatedly, until the distortion reading on the analyzer is less than 0.2%. Note that each one of these resistors contribute a small amount to the distortion correction. It is up to the service technician to find the most effective sequence to perform this step.
7. Disconnect the OUTPUT from the analyzer and repeat steps 3 and 4.

#### 7-3-3. Frequency Adjustment

Equipment: Counter, Oscilloscope, 50 ohms feedthrough termination

1. Change 8020 operating mode setting to VCO.
2. Change 8020 Frequency setting to 2.000 KHz.
3. Connect the OUTPUT terminal to the universal counter

input. Terminate counter input with 50 ohms feedthrough termination.

4. Set counter to frequency measurements and adjust R29 for a reading of 2.000 KHz +/- 10 Hz on the counter display.
5. Change 8020 Frequency setting to 20.00 KHz and check that the reading on the counter is 20.00 KHz +/- 30 Hz. If reading is not within the specified value readjust R29 so that the error in 2.000 KHz and 20.00 KHz is the same.
6. Change 8020 Frequency setting to 2.00 MHz.
7. Set counter and adjust C38 to give a reading of 2.00 MHz +/- 30 KHz on the counter display.
8. Set the oscilloscope to 20 mV/Div. and DC coupling and adjust the vertical trace line to be exactly at the center of the screen (0 V). Connect a 10:1 high frequency probe, with a very short ground lead, to the junction to TP7. Adjust the vertical gain of the oscilloscope so that the peak to peak amplitude on the screen will be exactly 6 divisions. Change 8020 frequency setting to 15.00 MHz. Select C56 and adjust C60 until peak to peak trace is 6 divisions +/- 1 small division. Note that the trace should be vertically symmetrical about the 0 V line.
9. Readjust C60 to give a reading of 15.00 MHz +/- 300 KHz on the counter display.
10. Change 8020 Frequency setting to 2.00 MHz.
11. Check with counter if reading is 2.00 MHz +/- 30 KHz. If reading is not within the specified value readjust C38.
12. Repeat steps 9 through 11 until best accuracy is achieved.
13. Change 8020 Frequency setting to 200.0 KHz.
14. Set counter and select C44 (approximately 330 PF) to give a reading of 200 KHz +/- 3 KHz on the counter display.
15. Change 8020 Frequency setting to 2.000 MHz.
16. Select C41 (approximately 47 PF) to give a reading of 2.00 MHz +/- 30 KHz on the counter display.

#### 7-3-4. Low Frequency Adjustment

Equipment: Counter

1. Change 8020 Frequency setting to 10.00 Hz.
2. Connect the 8020 OUTPUT terminal to the counter.
3. Adjust R59 to 10.00 Hz +/- .1 Hz.

#### 7-3-5. Low Frequency Distortion Adjustment

Equipment: Distortion analyzer, Counter

1. Change 8020 Frequency setting to 10.00 Hz.
2. Change 8020 Output setting to sine.
3. Connect 8020 OUTPUT terminal to the distortion analyzer input.
4. Adjust R44 for minimum distortion.

5. Disconnect the 8020 OUTPUT from the distortion analyzer and reconnect it to the counter input.
6. Change 8020 Output setting to squarewave.
7. Verify that the frequency reading on the counter is 10.00 Hz +/- .1 Hz. If reading is not within range, repeat steps 7-3-4 and 7-3-5 until all adjustments are within the specified range.

**7-3-6. Trigger Start Phase Adjustment**

Equipment: DMM

1. Change 8020 front panel settings as follows:  
Output setting to Triangle.  
Trigger setting to Gated.  
Amplitude setting to 15.0 V.
2. Connect DMM to 8022 output connector.
3. Set DMM and select R73 for a DMM reading of 0 V +/- .1 V.

**7-3-7. Amplitude Adjustment**

Equipment: DMM (RMS)

1. Change 8020 Amplitude setting to 15.0 V.
2. Change 8020 Frequency setting to 1.000 KHz.
3. Set DMM to ACV measurements and connect 8020 OUTPUT through a 50 ohms feedthrough termination to the DMM.
4. Set Output waveform and perform adjustments, on the amplifier board assembly, as in the following table:

<u>OUTPUT WAVEFORM</u>	<u>ADJUST- MENT</u>	<u>REQUIRE DMM READING</u>
Sine	R39	5.31V +/-20mV
Triangle	R38	4.33V +/-20mV
Positive Pulse	R127	3.75V +/-10mV
Negative Pulse	R126	3.75V +/-10mV
Square	—	7.50V +/-20mV

**7-3-8. Offset Adjustment**

Equipment: DMM, 50 ohms feedthrough termination

1. Change 8020 frequency setting to 1.000 KHz and amplitude setting to 1.00 V.
2. Change 8020 Offset setting to 7.00 V and turn offset on.
3. Set DMM to DCV measurements and connect 8020 OUTPUT, through a 50 ohms feedthrough termination to the DMM.

4. Adjust R99, on the amplifier board assembly to give a reading of 7.00 V +/-50 mV on the DMM.
5. Change 8020 offset setting to -7.00 V.
6. Verify that DMM reading is -7.00 mV +/-50 mV. If not within range re- adjust R99 to compromise between the two readings.

**7-3-9. Squarewave Response Adjustment**

Equipment: Oscilloscope, 50ohms feedthrough termination

1. Temporarily install C23 - 6.8 pF and C21 - 15 pF.
2. Change 8020 Frequency setting to 1.000 MHz.
3. Change 8020 Amplitude setting to 15.0 V.
4. Connect 8020 OUTPUT connector, through a 50 ohms feedthrough termination, to the oscilloscope input.
5. Set oscilloscope to 20 uS/Div. and adjust the Vertical control on the oscilloscope to display the square waveform in exactly 6 vertical divisions.
6. Change oscilloscope setting to 5 nS/Div.
7. Adjust C62, on the amplifier board assembly for the best rise/fall times and for minimum overshoot and undershot. If necessary, select C23 for best pulse response.
8. Change 8020 Amplitude setting to 1.50 V and verify that the response is within the limits. If necessary, re-select C21 for best pulse response.

**7-3-10. Sine Flatness Adjustments**

Equipment: Oscilloscope, 50ohms feedthrough termination

1. Change 8020 Function setting to Sine.
2. Change 8020 Frequency setting to 100.0 KHz.
3. Change 8020 Amplitude setting to 15.0 V.
4. Connect 8020 OUTPUT, through a 50 ohms feedthrough termination, to the oscilloscope.
5. Adjust oscilloscope controls to display the Sinewave with exactly 6 vertical divisions peak to peak.
6. Change 8020 Frequency setting to 20 MHz.
7. Select C6 (approximately 10 pF), on the amplifier board assembly, so that the sinewave amplitude on the screen will be within the range of 5.1 to 5.3 vertical divisions.

**7-3-11. Triangle Flatness Adjustments**

Equipment: Oscilloscope, 50 ohms feedthrough termination

1. Change 8020 Function setting to Triangle.
2. Change 8020 Frequency setting to 100.0 KHz.
3. Change 8020 Amplitude setting to 15.0 V.
4. Connect 8020 OUTPUT, through a 50 ohms feedthrough termination, to the oscilloscope.
5. Adjust oscilloscope controls to display the triangle with exactly 6 vertical divisions peak to peak.
6. Change 8020 Frequency setting to 20 MHz.
7. Select C7 (approximately 15PF), on the amplifier board assembly, so that the triangle amplitude on the screen will be within the range of 5.1 to 5.3 vertical divisions.

**7-3-12. Reference Oscillator Adjustment**

Equipment: Counter

1. Set counter for frequency measurements. Using a :10 probe, measure the frequency at pin 3 of U14.
2. Select C68, on the main board assembly, for a counter reading of 5.0000 MHz +/- 100 Hz.

**7-3-13. Pulse Width Adjustment (model 8021 only)**

Equipment: Counter

1. Connect 8021 output through a 50 ohms feedthrough termination to the counter input. Set counter and 8021 settings and adjust controls on the final amplifier board assembly, as follows:

<u>8021 WID</u>	<u>8021 FREQ</u>	<u>COUNTER</u>	
<u>SETTING</u>	<u>SETTING</u>	<u>ADJUST</u>	<u>READING</u>
5.00 mS	100.0 Hz	R211	5.00 mS +/-50 uS
500 uS	1.000 KHz	R211*	500 uS +/-5 uS
50.0 uS	10.00 KHz	C84	50.0 uS +/--.5 uS
500 nS	1.000 MHz	C89	500 nS +/-10 nS
25.0 nS	1.000 MHz	R188	25.0 nS +/-2 nS
(Repeat last two steps)			
5.00 uS	100.0 KHz	C86	5.00 uS +/-50 nS

\* Repeat adjustments until best accuracy is achieved.

**7-3-14. Ramp Amplitude Adjustment (model 8021 only)**

Equipment: Oscilloscope

1. Set 8021 output to ramp, frequency setting to 1.000 KHz, pulse width setting to 500 uS and amplitude setting to 6.0 V.
2. Set oscilloscope input to DC coupling and vertical gain to

be 1 V/div. Adjust trace vertical position so that it appears 3 divisions below the center line.

3. Connect 8021 output, through a 50 ohms feedthrough termination, to oscilloscope input. Select R218 so that the base line is set to three divisions below the center line.
4. Adjust R213 for a peak to peak amplitude of 6 vertical divisions.

**7-3-15. Amplitude Modulation Adjustment (model 8022 only)**

Equipment: Oscilloscope, function generator, DMM

1. Set 8022 output to AM mode on, frequency setting to 1.000 KHz, amplitude setting to 15.0 V, output setting to sine waveform and carrier setting to 0 %.
2. Connect 8022 output, through a 50 ohms feedthrough termination, to DMM input. Set DMM to ACV and 200 mV range. Adjust R135, on the final amplifier board, for a DMM reading of 0 V +/-20 mV.
3. Change 8022 carrier setting to 100 %. Adjust R174 for a DMM reading of 2.65 V +/-10 mV.
4. Change 8022 carrier setting to 0 % and trigger mode setting to TRIG.
5. Set external function generator to output sine waveform at 1.000 KHz and 4 Vp-p amplitude. Connect external generator to 8022 AM input and adjust R142 for a DMM reading of 0 V +/-20 mV. Remove external generator from 8022 AM input.
6. Change 8022 carrier setting to 100 % and gated mode. Set DMM to DCV and 200 mV range. Adjust R159 for a DMM reading of 0 V +/-20 mV. Disconnect 8022 output from DMM.
7. Set external function generator to output sine waveform at 1.000 KHz. Connect external function generator to 8022 AM input.
8. Connect 8022 output, through a 50 ohms feedthrough termination, to the oscilloscope. Connect 8022 SYNC output to oscilloscope external trigger input. Set oscilloscope to external trigger.
9. Change 8022 frequency setting to 1 MHz.
10. Adjust external function generator amplitude until the trace on the oscilloscope exhibits 100 % modulation. Re-adjust R142 for equal positive and negative portions of the modulated signal. Note and record peak to peak amplitude level.
11. Change 8022 carrier setting to 0 %. The oscilloscope now displays an SCAM waveform (suppressed carrier amplitude modulation). Modify external function generator amplitude so that the peak to peak amplitude is exactly as noted before. If necessary re-adjust R135 for equal positive and negative portions of the modulated signal.

**SECTION 8**

**PARTS LIST**

**8.1 GENERAL**

This section contains information for ordering replacement parts. The replacement parts are available from Tabor Electronics. Mechanical parts are shown separately on Figure 8-1.

- a) Instrument Model number.
- b) Instrument Serial number.
- c) Tabor part number.
- d) Part description.
- e) Circuit designation (where applicable).

**8.2 ORDERING INFORMATION**

When ordering replacement parts, always include the following information:

**8.3 PARTS DESCRIPTION**

In the following Parts List Tables, unless otherwise noted, resistors are 5% 1/4W, resistance is given in ohms, and capacitance is given in uF.

Table 8-1. Model 8020 Parts List - Main Board Assembly

<b>REF</b>	<b>DESCRIPTION</b>	<b>PART #</b>	<b>REF</b>	<b>DESCRIPTION</b>	<b>PART #</b>
C1	CAP CER .1 -20+80% 50V	1500-01040	C33	CAP CER 47P 20% 50V	1500-04700
C2	CAP CER .1 -20+80% 50V	1500-01040	C34	CAP CER 47P 20% 50V	1500-04700
C3	CAP CER .1 -20+80% 50V	1500-01040	C35	CAP TANT 10 35V	1540-0106A
C4	CAP CER .1 -20+80% 50V	1500-01040	C36	CAP TANT 10 35V	1540-0106A
C5	CAP CER .1 -20+80% 50V	1500-01040	C37	CAP MICA 220P 10% 500V	1510-02210
C6	CAP CER .1 -20+80% 50V	1500-01040	C38	CAP VAR 5-18P DV11PS18A	1550-01800
C7	CAP CER .1 -20+80% 50V	1500-01040	C40	CAP MICA 820P 10% 300V	1510-08210
C8	CAP CER .1 -20+80% 50V	1500-01040	C42	CAP POLY 4700P 2% 160V	1520-04720
C9	CAP CER .1 -20+80% 50V	1500-01040	C43	CAP POLY 4700P 2% 160V	1520-04720
C10	CAP CER .1 -20+80% 50V	1500-01040	C45	CAP POLY .1 1% 63V	1520-01040
C11	CAP CER .1 -20+80% 50V	1500-01040	C46	CAP POLY 1 1% 63V	1520-01050
C12	CAP CER .1 -20+80% 50V	1500-01040	C47	CAP CER .1 -20+80% 50V	1500-01040
C13	CAP CER .1 -20+80% 50V	1500-01040	C48	CAP CER .1 -20+80% 50V	1500-01040
C14	CAP ELEC 2200 25V	1533-02280	C49	CAP CER .1 -20+80% 50V	1500-01040
C15	CAP ELEC 2200 25V	1533-02280	C50	CAP CER .1 -20+80% 50V	1500-01040
C16	CAP ELEC 100 25V	1533-01070	C51	CAP CER .1 -20+80% 50V	1500-01040
C17	CAP ELEC 100 25V	1533-01070	C52	CAP TANT 10 35V	1540-0106A
C18	CAP ELEC 1000 50V	1535-01080	C53	CAP CER .1 -20+80% 50V	1500-01040
C19	CAP ELEC 1000 50V	1535-01080	C54	CAP TANT 10 35V	1540-0106A
C20	CAP ELEC 100 25V	1533-01070	C55	CAP CER 33P 20% 50V	1500-03300
C21	CAP ELEC 100 25V	1533-01070	C57	CAP CER 47P 20% 50V	1500-04700
C22	CAP ELEC 470 16V	1532-04770	C58	CAP CER 22P 20% 50V	1500-02200
C23	CAP ELEC 10000 16V	1532-01090	C59	CAP CER 47P 20% 50V	1500-04700
C24	CAP ELEC 220 16V	1532-02270	C60	CAP VAR 7-40P 5MM	1550-02000
C25	CAP CER 33P 20% 50V	1500-03300	C61	CAP CER .1 -20+80% 50V	1500-01040
C26	CAP CER 1n 20% 50V	1500-01020	C62	CAP CER .1 -20+80% 50V	1500-01040
C27	CAP CER .1 -20+80% 50V	1500-01040	C63	CAP CER .1 -20+80% 50V	1500-01040
C28	CAP CER 56P 20% 50V	1500-05600	C64	CAP POLY 2.2 63V 5%	1522-02250
C29	CAP CER 47P 20% 50V	1500-04700	C65	CAP CER .1 -20+80% 50V	1500-01040
C30	CAP CER 47P 20% 50V	1500-04700	C66	CAP CER .1 -20+80% 50V	1500-01040
C31	CAP CER 1n 20% 50V	1500-01020	C67	CAP CER .1 -20+80% 50V	1500-01040
C32	CAP CER 1n 20% 50V	1500-01020	C68	CAP MICA SELECTED (12P TYP.)	

Table 8-1. Model 8020 Parts List - Main Board Assembly (continued)

REF	DESCRIPTION	PART#	REF	DESCRIPTION	PART#
C69	CAP CER .1 -20+80% 50V	1500-01040	Q16	TSTR 2N3904A	0400-01200
C70	CAP CER .1 -20+80% 50V	1500-01040	Q17	TSTR 2N3904A	0400-01200
C71	CAP CER .1 -20+80% 50V	1500-01040	Q18	TSTR 2N3904A	0400-01200
C72	CAP CER .1 -20+80% 50V	1500-01040	Q19	TSTR DN5566	0400-40500
C73	CAP CER .1 -20+80% 50V	1500-01040	Q20	TSTR 2N3646	0400-00200
C74	CAP TANT 1035V	1540-0106A	Q21	TSTR 2N3646	0400-00200
C76	CAP CER .1 -20+80% 50V	1500-01040	Q22	TSTR 2N5771	0400-00750
C77	CAP CER .1 -20+80% 50V	1500-01040	Q23	TSTR 2N3646	0400-00200
			Q24	TSTR 2N3646	0400-00200
CR1	DIODE BRIDGE WS05	0300-50100	Q25	TSTR 2N5771	0400-00750
CR2	DIODE BRIDGE WS05	0300-50100	Q26	TSTR 2N3906A	0400-01340
CR3	DIODE BRIDGE KBL-005	0300-50200	Q27	TSTR MPS3827	0400-02820
CR4	DIODE 1N4151	0300-00400	Q28	TSTR 2N5771	0400-00750
CR5	DIODE SA-5A	0300-90300	Q29	TSTR 2N5771	0400-00750
CR6	DIODE 1N4151	0300-00400	Q30	TSTR 2N4122	0400-00500
CR7	DIODE 1N4151	0300-00400	Q31	TSTR 2N3904A	0400-01200
CR8	DIODE ZENER 1N758A	0300-20400	Q32	TSTR J109	0400-02500
CR9	DIODE ZENER 1N755	0300-20310	Q33	TSTR 2N3906A	0400-01340
CR10	DIODE 1N4151	0300-00400	Q34	TSTR 2N4122	0400-00500
CR11	DIODE 1N4151	0300-00400	Q35	TSTR MPS3827	0400-02820
CR12	DIODE 1N4151	0300-00400	Q36	TSTR 2N5771	0400-00750
CR13	DIODE REF 1N825A	0300-21100	Q37	TSTR 2N5771	0400-00750
CR14	DIODE ZENER 1N758A	0300-20400	Q38	TSTR 2N3904A	0400-01200
CR15	DIODE 1N4151	0300-00400	Q39	TSTR 2N3904A	0400-01200
CR16	DIODE ZENER 1N758A	0300-20400	Q40	TSTR 2N4124	0400-00300
CR17	DIODE 5082-2810	0300-10200	Q43	TSTR J109	0400-02500
CR18	DIODE 5082-2810	0300-10200			
CR19	DIODE 5082-2810	0300-10200	R1	RES COMP 3.3K	0100-03320
CR20	DIODE 5082-2810	0300-10200	R2	RES MTF 249 1%	0104-24900
CR21	DIODE 5082-2810	0300-10200	R3	RES MTF 2.49K 1%	0104-24910
CR22	DIODE 5082-2810	0300-10200	R4	RES VAR 500 3386F	0203-05010
CR23	DIODE 1N4151	0300-00400	R5	RES COMP 1K	0100-01020
CR24	DIODE 1N4151	0300-00400	R6	RES COMP .27 2W	0103-0R270
CR25	DIODE 1N4151	0300-00400	R7	RES COMP 1K	0100-01020
CR26	DIODE ZENER 1N754A	0300-20300	R8	RES COMP 100	0100-01010
CR27	DIODE ZENER 1N753A	0300-20200	R9	RES COMP 1K	0100-01020
CR28	DIODE 5082-2810	0300-10200	R10	RES MTF 4.02K 1%	0104-40210
CR29	DIODE 5082-2810	0300-10200	R11	RES MTF 15K 1%	0104-15020
CR30	DIODE ZENER 1N754A	0300-20300	R12	RES COMP 220	0100-02210
CR31	DIODE 1N4151	0300-00400	R13	RES COMP 47	0100-04700
CR32	DIODE 1N4151	0300-00400	R14	RES COMP 33	0100-03300
CR33	DIODE ZENER 1N753A	0300-20200	R15	RES COMP 1K	0100-01020
CR34	DIODE 1N4151	0300-00400	R16	RES MTF 499 .1%	0105-49900
CR35	DIODE ZENER 1N759A	0300-20500	R17	RES MTF 499 .1%	0105-49900
CR36	DIODE 1N4151	0300-00400	R18	RES COMP 1K	0100-01020
CR37	DIODE 1N4151	0300-00400	R19	RES MTF 249 1%	0104-24900
			R20	RES COMP 1K	0100-01020
Q1	TSTR 2N4401	0400-01810	R21	RES MTF 499 .1%	0105-49900
Q2	TSTR 2N3904A	0400-01200	R22	RES MTF 499 .1%	0105-49900
Q3	TSTR MJE2955A	0400-40300	R23	RES MTF 1.1K 1%	0104-11010
Q4	TSTR 2N3906A	0400-01340	R24	RES MTF 1K 1%	0104-10010
Q5	TSTR 2N3904A	0400-01200	R25	RES MTF 105 1%	0104-10500
Q6	TSTR 2N5087	0400-01900	R26	RES COMP 33K	0100-03330
Q7	TSTR 2N5210	0400-01910	R28	RES MTF 10K 1%	0104-10020
Q8	TSTR 2N3904A	0400-01200	R29	RES VAR 5K 3386F-1-502	0203-05020
Q9	TSTR 2N5087	0400-01900	R30	RES COMP 1.5K	0100-01520
Q10	TSTR 2N5210	0400-01910	R32	RES MTF 4.99K 1%	0104-09910
Q11	TSTR 2N3904A	0400-01200	R34	RES COMP 620	0100-06210
Q12	TSTR J109	0400-02500	R35	RES COMP 100	0100-01010
Q13	TSTR 2N3906A	0400-01340	R36	RES COMP 10K	0100-01030
Q15	TSTR 2N3904A	0400-01200	R38	RES COMP 100	0100-01010

Table 8-1. Model 8020 Parts List - Main Board Assembly (continued)

<u>REF</u>	<u>DESCRIPTION</u>	<u>PART #</u>	<u>REF</u>	<u>DESCRIPTION</u>	<u>PART #</u>
R39	RES COMP 100K	0100-01040	R107	RESMTF 4.53K 1%	0104-45310
R42	RESMTF 1K 1%	0104-10010	R108	RES COMP 3.9K	0100-03920
R43	RESMTF 10K 1%	0104-10020	R109	RES COMP 10K	0100-01030
R44	RES VAR 10K 3386F	0203-01030	R110	RES COMP 1.2K	0100-01220
R45	RES COMP 100	0100-01010	R111	RES COMP 10K	0100-01030
R46	RESMTF 1M 1%	0104-10040	R112	RES COMP 100	0100-01010
R47	RESMTF 100K 1%	0104-10030	R113	RES COMP 15	0100-01500
R48	RES COMP 10K	0100-01030	R114	RESMTF 4.99K 1%	0104-49910
R49	RESMTF 1.1K 1%	0104-11010	R115	RES VAR 50K 3386F	0203-05030
R50	RES COMP 1M	0100-01050	R116	RES COMP 33	0100-03300
R51	RES COMP 1M	0100-01050	R117	RESMTF 49.9 1%	0104-49R90
R52	RES COMP 3.3K	0100-03320	R118	RES COMP 220	0100-02210
R53	RES COMP 100	0100-01010	R120	RES COMP 100K	0100-01040
R54	RES COMP 100	0100-01010	R121	RES COMP 33	0100-03300
R55	RESMTF 47.5K 1%	0104-47520	R122	RES COMP 10K	0100-01030
R56	RESMTF 10K 1%	0104-10020	R123	RES COMP 22K	0100-02230
R58	RES COMP 3.3K	0100-03320	R124	RES COMP 33	0100-03300
R59	RES VAR 10K 3386F	0203-01030	R126	RESMTF 1.13K 1%	0104-11310
R61	RES COMP 1K	0100-01020	R128	RESMTF 140 1%	0104-14100
R62	RES COMP 1K	0100-01020	R129	RES COMP 1K	0100-01020
R63	RES COMP 1K	0100-01020	R130	RESMTF 9.09K 1%	0104-90910
R64	RES COMP 1K	0100-01020	R131	RESMTF 4.99K 1%	0104-49910
R65	RES COMP 33	0100-03300	R132	RES COMP 560	0100-05610
R66	RES COMP 51	0100-05100	R133	RES COMP 560	0100-05610
R67	RES COMP 100	0100-01010	R134	RES COMP 33	0100-03300
R68	RES COMP 100	0100-01010	R135	RES COMP 100	0100-01010
R69	RES COMP 3.9K	0100-03920	R136	RESMTF 619 1%	0104-61900
R70	RES COMP 39	0100-03900	R137	RES COMP 270	0100-02710
R71	RESMTF 100 1%	0104-10000	R138	RESMTF 115 1%	0104-11500
R72	RESMTF 127 1%	0104-12700	R139	RES COMP 100	0100-01010
R73	RES SELECTED		R140	RES COMP 33	0100-03300
R74	RES COMP 1.2K	0100-01220	R141	RES COMP 100	0100-01010
R75	RES COMP 39	0100-03900	R142	RESMTF 1.87K 1%	0104-18710
R76	RES COMP 2.7K	0100-02720	R143	RES COMP 270	0100-02710
R77	RES COMP 2.7K	0100-02720	R144	RESMTF 154 1%	0104-15400
R78	RES COMP 39	0100-03900	R145	RESMTF 140 1%	0104-14100
R79	RES COMP 1.2K	0100-01220	R146	RESMTF 115 1%	0104-11500
R80	RES COMP 7.5K	0100-07520	R147	RESMTF 7.32K 1%	0104-73210
R81	RES COMP 33	0100-03300	R148	RESMTF 154 1%	0104-15400
R82	RES COMP 7.5K	0100-07520	R149	RESMTF 825 1%	0104-82500
R83	RES COMP 33	0100-03300	R150	RESMTF 49.9 1%	0104-49R90
R84	RES COMP 15K	0100-01530	R151	RES COMP 33	0100-03300
R86	RES COMP 2.7	0100-02R70	R152	RESMTF 261 1%	0104-26100
R87	RES COMP 15K	0100-01530	R154	RESMTF 127 1%	0104-12700
R88	RESMTF 976 1%	0104-97600	R155	RES COMP 270	0100-02710
R89	RESMTF 976 1%	0104-97600	R156	RESMTF 261 1%	0104-26100
R90	RES COMP 390	0100-03910	R157	RES COMP 33	0100-03300
R91	RES COMP 820	0100-08210	R159	RESMTF 127 1%	0104-12700
R92	RES COMP 820	0100-08210	R160	RESMTF 499 1%	0104-49900
R93	RES COMP 82	0100-08200	R161	RES COMP MTF 1.5K 1%	0104-15010
R94	RES COMP 82	0100-08200	R162	RESMTF 100 1%	0104-10000
R95	RES COMP 39	0100-03900	R163	RESMTF 4.02K 1%	0104-40210
R96	RES COMP 10	0100-01000	R164	RES COMP 10	0100-01000
R97	RES COMP 68	0100-06800	R165	RES COMP 10	0100-01000
R100	RES COMP 10	0100-01000	R166	RES COMP MTF 1.5K 1%	0104-15010
R101	RESMTF 365 1%	0104-36500	R167	RESMTF 499 1%	0104-49900
R102	RESMTF 365 1%	0104-36500	R168	RES COMP 100	0100-01010
R103	RES COMP 1.2K	0100-01220	R169	RES COMP 51	0100-05100
R104	RES COMP 1.2K	0100-01220	R170	RES COMP 820	0100-08210
R106	RESMTF 4.53K 1%	0104-45310	R171	RES COMP 51	0100-05100

Table 8-1. Model 8020 Parts List - Main Board Assembly (continued)

REF	DESCRIPTION	PART#	REF	DESCRIPTION	PART#
R172	RES VAR 2K 3386F	0203-02020	U22	IC 74LS00	0510-00100
R174	RES COMP 1K	0100-01020	U23	IC 74F00	0500-11900
R175	RES COMP 10K	0100-01030	U25	IC LM308A	0500-53400
R176	RES COMP 10K	0100-01030	U26	IC LM308A	0500-53400
R177	RES COMP 100K	0100-01040	U27	IC LM308A	0500-53400
R178	RES COMP 10K	0100-01030	U28	IC LM308A	0500-53400
U1	IC BFER 9668 (L204)	0500-11600	U29	IC CD4094B	0540-01100
U2	IC P8279	0500-20700	U30	IC CD4094B	0540-01100
U3	IC 74HC4049	0520-07300	U31	IC CD4094B	0540-01100
U4	IC 74LS138	0510-02700	U33	IC LM741C	0500-56310
U5	IC P8031	0500-21410	U34	IC 12 BIT D/A AD7541AJN	0560-00800
U6	IC SN74HC4040	0520-07000	U35	IC 10 BIT D/A AD7533JN	0560-00700
U7	IC 74LS373	0510-03650	U36	IC LM741C	0500-56310
U8	IC 27256	0500-21240	U37	IC LM741C	0500-56310
U9	IC MK48ZO2B-20	0500-11160	U38	IC CD4094B	0540-01100
U10	IC 74HCT4040 PLL	0520-07200	U39	IC QUAD OP AMP LM324	0500-53210
U11	IC 74LS00	0510-00100	U40	IC OP AMP TL081CP	0500-56700
U12	IC 74LS74	0510-01100	U41	IC LM741C	0500-56310
U13	IC 74LS51	0510-00810	U42	IC ANALOG SW DG211CJ	0500-90900
U14	IC P8291A	0500-21300	U43	IC ARRAY CA3102BE	0500-57700
U15	IC BUFFER DS75160N	0500-21510	U44	IC LM741C	0500-56310
U16	IC BUFFER DS75161N	0500-21520	U45	IC ARRAY CA3127E	0500-60000
U17	IC REGULATOR MC7924CP	0500-52700	U46	IC ARRAY CA3127E	0500-60000
U18	IC REGULATOR MC7824CP	0500-52600	U47	IC ARRAY CA3127E	0500-60000
U19	IC REGULATOR MC7915CP	0500-52500	U48	IC OP AMP CA3140E	0500-57200
U20	IC REGULATOR LM317T	0500-53600	U49	IC ANALOG SW DG211CJ	0500-90900
U21	IC OP AMP LM308A	0500-53400			

Table 8-2. Model 8020 Parts List - Final Amplifier Board Assembly

REF	DESCRIPTION	PART#	REF	DESCRIPTION	PART#
C1	CAP CER .1 -20%+80% 50V	1500-01040	C31	CAP CER 1n 20% 50V	1500-01020
C4	CAP CER .1 -20%+80% 50V	1500-01040	C32	CAP CER 1n 20% 50V	1500-01020
C5	CAP CER .1 -20%+80% 50V	1500-01040	C33	CAP CER 100P 20% 50V	1500-01010
C6	SELECTED		C34	CAP CER 1n 20% 50V	1500-01020
C7	SELECTED		C36	CAP CER .1 -20%+80% 50V	1500-01040
C8	CAP CER .1 -20%+80% 50V	1500-01040	C37	CAP CER 1n 20% 50V	1500-01020
C10	CAP CER .1 -20%+80% 50V	1500-01040	C38	CAP CER 1n 20% 50V	1500-01020
C11	CAP CER .1 -20%+80% 50V	1500-01040	C39	CAP CER 1n 20% 50V	1500-01020
C12	CAP CER .1 -20%+80% 50V	1500-01040	C41	CAP CER 10P 20% 50V	1500-01000
C13	CAP CER .1 -20%+80% 50V	1500-01040	C42	CAP CER .1 -20%+80% 50V	1500-01040
C14	CAP CER 15P 20% 50V	1500-01500	C43	CAP CER .1 -20%+80% 50V	1500-01040
C16	CAP CER .1 -20%+80% 50V	1500-01040	C44	CAP CER 33P 20% 50V	1500-03300
C17	CAP CER .1 -20%+80% 50V	1500-01040	C45	CAP CER .1 -20%+80% 50V	1500-01040
C18	CAP CER .1 -20%+80% 50V	1500-01040	C46	CAP CER .1 -20%+80% 50V	1500-01040
C19	CAP CER .1 -20%+80% 50V	1500-01040	C47	CAP CER .1 -20%+80% 50V	1500-01040
C20	CAP CER .1 -20%+80% 50V	1500-01040	C48	CAP CER .1 -20%+80% 50V	1500-01040
C21	SELECTED		C49	CAP CER .1 -20%+80% 50V	1500-01040
C22	CAP CER 27P 20% 63V	1500-02700	C50	CAP CER .1 -20%+80% 50V	1500-01040
C23	SELECTED		C51	CAP CER 100P 20% 50V	1500-01010
C24	CAP CER .1 -20%+80% 50V	1500-01040	C52	CAP CER .1 -20%+80% 50V	1500-01040
C25	CAP CER .1 -20%+80% 50V	1500-01040	C53	CAP CER .1 -20%+80% 50V	1500-01040
C26	CAP CER .1 -20%+80% 50V	1500-01040	C54	CAP CER .1 -20%+80% 50V	1500-01040
C27	CAP CER .1 -20%+80% 50V	1500-01040	C55	CAP CER .1 -20%+80% 50V	1500-01040
C28	CAP CER 1n 20% 50V	1500-01020	C56	CAP CER .1 -20%+80% 50V	1500-01040
C29	CAP CER 1n 20% 50V	1500-01020	C57	CAP CER 43P 20% 50V	1500-04300
C30	CAP CER 4.7P 20% 50V	1500-04R70	C58	CAP TANT 1035V	1540-0106A

Table 8-2. Model 8020 Parts List - Final Amplifier Board Assembly (continued)

<u>REF</u>	<u>DESCRIPTION</u>	<u>PART #</u>	<u>REF</u>	<u>DESCRIPTION</u>	<u>PART #</u>
C59	CAP POLY.1 20% 100V	1521-01040	Q26	TSTR 2N4392A	0400-40000
C60	CAP TANT 10 35V	1540-0106A	Q27	TSTR J175	0400-02520
C61	CAP POLY.1 20% 100V	1521-01040	Q28	TSTR 2N4392A	0400-40000
C62	CAP VAR 5-18P DV11PS18A	1550-01800	Q29	TSTR J175	0400-02520
C63	CAP CER .1 -20%+80% 50V	1500-01040	Q30	TSTR 2N4392A	0400-40000
C64	CAP CER 33P 20% 50V	1500-03300	Q31	TSTR J175	0400-02520
CR1	DIODE ZENER 1N754A	0300-20300	Q32	TSTR 2N4392A	0400-40000
CR2	DIODE ZENER 1N754A	0300-20300	Q33	TSTR 2N3646	0400-00200
CR3	DIODE 1N4151	0300-00400	Q34	TSTR 2N3640	0400-00100
CR4	DIODE 1N4151	0300-00400	Q35	TSTR J109	0400-02500
CR5	DIODE 1N4151	0300-00400	Q36	TSTR 2N3904A	0400-01200
CR6	DIODE ZENER 1N751A	0300-20010	Q37	TSTR 2N3906A	0400-01340
CR7	DIODE 1N4151	0300-00400	Q38	TSTR 2N5160A	0400-00800
CR8	DIODE 1N4151	0300-00400	Q39	TSTR 2N3866A	0400-01610
CR9	DIODE 1N4151	0300-00400	Q40	TSTR 2N3904A	0400-01200
CR10	DIODE 1N4151	0300-00400	Q41	TSTR 2N4122	0400-00500
CR11	DIODE 1N4151	0300-00400	Q42	TSTR 2N3904A	0400-01200
CR12	DIODE 1N4151	0300-00400	Q43	TSTR 2N2219A	0400-40100
CR13	DIODE 1N4151	0300-00400	Q44	TSTR 2N2219A	0400-40100
CR14	DIODE 1N4151	0300-00400	Q45	TSTR 2N2905A	0400-01500
CR15	DIODE 1N4151	0300-00400	Q46	TSTR 2N2905A	0400-01500
CR16	DIODE 1N4151	0300-00400	R1	RES COMP 180	0100-01810
CR17	DIODE 1N4151	0300-00400	R2	RES COMP 180	0100-01810
CR18	DIODE 1N4151	0300-00400	R5	RES COMP 33K	0100-03330
CR19	DIODE 1N4151	0300-00400	R6	RES COMP 100K	0100-01040
CR20	DIODE 1N4151	0300-00400	R8	RES COMP 1.2K	0100-01220
CR21	DIODE REF 1N825A	0300-21100	R9	RES COMP 1.2K	0100-01220
CR22	DIODE 1N4151	0300-00400	R10	RES COMP 560	0100-05610
CR23	DIODE 1N4151	0300-00400	R11	RES COMP 120	0100-01210
CR24	DIODE 1N4151	0300-00400	R12	RES COMP 120	0100-01210
CR25	DIODE ZENER 1N758A	0300-20400	R13	RES COMP 33K	0100-03330
K1	RELAY RZ-1	0900-00700	R14	RES COMP 100K	0100-01040
K2	RELAY RZ-1	0900-00700	R15	RES MTF 1K 1%	0104-10010
K3	RELAY RZ-1	0900-00700	R16	RES MTF 1K 1%	0104-10010
Q1	TSTR 2N5771	0400-00750	R17	RES MTF 10K 1%	0104-10020
Q2	TSTR 2N5771	0400-00750	R18	RES MTF 15K 1%	0104-15020
Q3	TSTR 2N3646	0400-00200	R19	RES COMP 1K	0100-01020
Q4	TSTR 2N3646	0400-00200	R20	RES MTF 10K 1%	0104-10020
Q5	TSTR 2N4126	0400-00400	R21	RES MTF 15K 1%	0104-15020
Q6	TSTR J109	0400-02500	R22	RES COMP 1K	0100-01020
Q7	TSTR 2N4124	0400-00300	R23	RES COMP 33K	0100-03330
Q8	TSTR J109	0400-02500	R24	RES COMP 33K	0100-03330
Q9	TSTR 2N4124	0400-00300	R25	RES COMP 3.3K	0100-03320
Q10	TSTR 2N4126	0400-00400	R26	RES COMP 3.3K	0100-03320
Q12	TSTR SD214DE	0400-02310	R27	RES COMP 15K	0100-01530
Q13	TSTR 2N3904A	0400-01200	R28	RES MTF 402 1%	0104-40200
Q14	TSTR 2N3906A	0400-01340	R29	RES MTF 100 1%	0104-10000
Q15	TSTR 2N3904A	0400-01200	R30	RES COMP 3.9K	0100-03920
Q16	TSTR 2N3906A	0400-01340	R31	RES COMP 2.7K	0100-02720
Q17	TSTR 2N4392A	0400-40000	R32	RES COMP 1K	0100-01020
Q18	TSTR SD 214DE	0400-02310	R33	RES COMP 2.7K	0100-02720
Q19	TSTR 2N4392A	0400-40000	R34	RES COMP 1K	0100-01020
Q20	TSTR SD 214DE	0400-02310	R35	RES COMP 820	0100-08210
Q21	TSTR 2N4392A	0400-40000	R36	RES COMP 1K	0100-01020
Q22	TSTR SD 214DE	0400-02310	R37	RES COMP 15K	0100-01530
Q23	TSTR 2N4392A	0400-40000	R38	RES VAR 100 3386F	0203-01010
Q24	TSTR SD 214DE	0400-02310	R39	RES VAR 200 3329H	0201-02010
Q25	TSTR J175	0400-02520	R40	RES COMP 220	0100-02210
			R41	RES COMP 22	0100-01500
			R42	RES COMP 270	0100-02710



Table 8-2. Model 8020 Parts List - Final Amplifier Board Assembly (continued)

<b>REF</b>	<b>DESCRIPTION</b>	<b>PART#</b>	<b>REF</b>	<b>DESCRIPTION</b>	<b>PART#</b>
R43	RES COMP 100	0100-01010	R99	RES VAR 2K 3386F	0203-02020
R44	RES COMP 4.7K	0100-04720	R100	RES MTF 1K 1%	0104-10010
R45	RES COMP 18K	0100-01830	R101	RES COMP 1K	0100-01020
R46	RES COMP 10	0100-01000	R102	RES MTF 10K 1%	0104-10020
R47	RES COMP 10	0100-01000	R103	RES COMP 33K	0100-03330
R48	RES COMP 22	0100-02200	R104	RES COMP 10K	0100-01030
R49	RES COMP 225%	0100-02200	R105	RES COMP 10K	0100-01030
R50	RES COMP 33K	0100-03330	R106	RES COMP 2.7K	0100-02720
R51	RES COMP 4.7K	0100-04720	R107	RES COMP 2.7K	0100-02720
R52	RES COMP 390	0100-03910	R108	RES COMP 3.9K	0100-03920
R53	RES COMP 225%	0100-02200	R109	RES COMP 470	0100-04710
R54	RES.MTF 294 1%	0104-29400	R110	RES COMP 33 2W	0103-03300
R55	RES COMP 220	0100-02210	R111	RES COMP 33	0100-03300
R56	RES MTF 681 1%	0104-68100	R112	RES COMP 33	0100-03300
R57	RES MTF 365 1%	0104-36500	R113	RES COMP 10	0100-01000
R58	RES MTF 365 1%	0104-36500	R114	RES COMP 10	0100-01000
R59	RES MTF 732 1%	0104-73200	R115	RES MTF 100 1% 1W	0104-1000B
R60	RES MTF 750 1%	0104-75100	R116	RES MTF 100 1% 1W	0104-1000B
R61	RES MTF 732 1%	0104-73200	R117	RES COMP 10	0100-01000
R62	RES MTF 750 1%	0104-75100	R118	RES COMP 10	0100-01000
R63	RES MTF 365 1%	0104-36500	R119	RES COMP 33 2W	0103-03300
R64	RES MTF 732 1%	0104-73200	R120	RES MTF 61.9 1% 1W	0104-61R9B
R65	RES COMP 100K	0100-01040	R121	RES MTF 249 1% 1/2W	0104-2490A
R66	RES MTF 40.2K 1%	0104-40220	R122	RES MTF 61.9 1% 1W	0104-61R9B
R67	RES MTF 750 1%	0104-75100	R123	RES MTF 1% 1W 96.5	0104-96R5B
R68	RES MTF 130 1%	0104-13100	R124	RES MTF 71.5 1/2W 1%	0104-71R5A
R69	RES COMP 100K	0100-01040	R125	RES MTF 1% 1W 96.5	0104-96R5B
R70	RES MTF 12.1K 1%	0104-12120	R126	RES VAR 5K 3386F	0203-05020
R71	RES COMP 2.7	0100-02R70	R127	RES VAR 5K 3386F	0203-05020
R72	RES MTF 22.1K 1%	0104-22120	R128	RES COMP 1K	0100-01020
R73	RES MTF 2K 1%	0104-20010	R129	RES COMP 47	0100-04700
R74	RES COMP 100K	0100-01040	RN1	RES NET 33K/5	0110-0333B
R75	RES MTF 47.5K 1%	0104-47520	RN2	RES NET 33K/5	0110-0333B
R76	RES MTF 511 1%	0104-51100	RN3	RES NET 33K/5	0110-0333B
R77	RES COMP 100K	0100-01040	RN4	RES NET 33K/5	0110-0333B
R78	RES MTF 5.11K 1%	0104-51110	U1	IC TRIPLE LINE REC 10107	0500-41100
R79	RES MTF 597 1%	0104-59700	U2	IC LM741C	0500-56310
R80	RES MTF 90.9K 1%	0104-90920	U3	IC LM741C	0500-56310
R81	RES COMP 1.8K	0100-01820	U4	IC REGISTER CD4094B	0540-01100
R82	RES COMP 3.9K	0100-03920	U5	IC QUAD COMP LM339N	0500-50400
R83	RES COMP 100	0100-01010	U6	IC QUAD COMP LM339N	0500-50400
R84	RES MTF 165%	0104-16500	U7	IC QUAD COMP LM339N	0500-50400
R85	RES COMP 185%	0100-01800	U8	IC REGISTER CD4094B	0540-01100
R86	RES MTF 750 1%	0104-75100	U9	IC QUAD COMP LM339N	0500-50400
R87	RES COMP 5.6K	0100-05620	U10	IC DMOS SW SD5000N	0500-57110
R88	RES MTF 750 1%	0104-75100	U11	IC TRANS ARRAY CA3096	0500-5790
R89	RES COMP 1K	0100-01020	U12	IC COMPARATOR LM311N	0500-53300
R90	RES COMP 270	0100-02710	U13	IC REGISTER CD4094B	0540-01100
R91	RES COMP 3.9K	0100-03920	U14	IC 10 BIT D/A AD7533JN	0560-00700
R92	RES COMP 100	0100-01010	U15	IC LM308A	0500-53400
R93	RES MTF 226 1%	0104-22600	U16	IC LM301AH	0500-53000
R94	RES COMP 155%	0100-01500	U17	IC LM741C	0500-56310
R95	RES COMP 1K	0100-01020	U18	IC TRANS ARRAY CA3096	0500-57900
R96	RES COMP 1K	0100-01020	U19	IC REGISTER CD4094B	0540-01100
R97	RES MTF 10K 1%	0104-10020	U20	IC BUFFER 9668 (L204)	0500-11600
R98	RES COMP 10K	0100-01030			

Table 8-3. Model 8021 Parts List - Front Panel Board Assembly

REF	DESCRIPTION	PART #	REF	DESCRIPTION	PART #
C1	CAPELEC 470 16V	1532-04770	DS23	LED RED MV 57124-18 G.I	1000-00700
C2	CAP CER .1 -20%+80% 50V	1500-01040	DS24	LED RED MV 57124-18 G.I	1000-00700
CR1	DIODE 1N4151	0300-00400	DS25	LED RED MV 57124-18 G.I	1000-00700
CR2	DIODE 1N4151	0300-00400	DS26	LED RED MV 57124-18 G.I	1000-00700
CR3	DIODE 1N4151	0300-00400	DS27	LED RED MV 57124-18 G.I	1000-00700
DS1	LED HDSP 7501 7 SEG 6020	1200-10200	DS28	3MM LED RED 5082-4480	1000-00300
DS2	LED HDSP 7501 7 SEG 6020	1200-10200	Q1	TSTR 2N4403	0400-01800
DS3	LED HDSP 7501 7 SEG 6020	1200-10200	Q2	TSTR 2N4403	0400-01800
DS4	LED HDSP 7501 7 SEG 6020	1200-10200	Q3	TSTR 2N4403	0400-01800
DS5	3MM LED RED 5082-4480	1000-00300	Q4	TSTR 2N4403	0400-01800
DS6	3MM LED RED 5082-4480	1000-00300	Q5	TSTR 2N4403	0400-01800
DS7	LED RED MV 57124-18 G.I	1000-00700	Q6	TSTR 2N4403	0400-01800
DS8	LED RED MV 57124-18 G.I	1000-00700	Q7	TSTR 2N4403	0400-01800
DS9	LED RED MV 57124-18 G.I	1000-00700	Q8	TSTR 2N4403	0400-01800
DS10	LED RED MV 57124-18 G.I	1000-00700	R1	RES COMP 220	0100-02210
DS11	3MM LED RED 5082-4480	1000-00300	R2	RES COMP 220	0100-02210
DS12	LED RED MV 57124-18 G.I	1000-00700	R3	RES COMP 220	0100-02210
DS13	LED RED MV 57124-18 G.I	1000-00700	R4	RES COMP 220	0100-02210
DS14	LED RED MV 57124-18 G.I	1000-00700	R5	RES COMP 33	0100-03300
DS15	LED RED MV 57124-18 G.I	1000-00700	R6	RES COMP 220	0100-02210
DS16	LED RED MV 57124-18 G.I	1000-00700	R7	RES COMP 33	0100-03300
DS17	LED HDSP 7507 +/- 16020	1200-10100	R8	RES COMP 220	0100-02210
DS18	LED HDSP 7501 7 SEG 6020	1200-10200	R9	RES COMP 220	0100-02210
DS19	LED RED MV 57124-18 G.I	1000-00700	R10	RES COMP 220	0100-02210
DS20	LED RED MV 57124-18 G.I	1000-00700	S1-S18	SWITCH KEY	2000-61600
DS21	LED RED MV 57124-18 G.I	1000-00700	U1	IC 74LS138	0510-02700
DS22	LED RED MV 57124-18 G.I	1000-00700			

Table 8-4. Model 8021 Parts List - Pulse Generator Board Assembly

REF	DESCRIPTION	PART #	REF	DESCRIPTION	PART #
C79	CAPTANT 10 35V	1540-0106A	C103	CAP CER .1 -20%+80% 50V	1500-01040
C80	CAPPOL 1 1% 63V	1520-01050	C104	CAP CER .1 -20%+80% 50V	1500-01040
C81	CAP POLY .1 1% 63V FKE	1520-01040	C105	CAP CER .1 -20%+80% 50V	1500-01040
C82	CAP POLY 4700P 2% 160V	1520-04720	C106	CAP ELECT 100 16V LOW LEAK	1532-0107P
C83	CAP POLY 4700P 2% 160V	1520-04720	CR35	DIODE CARRIER 5082-2810	0300-10200
C84	SELECTED VALUE (560P MICA TYP)		CR36	DIODE ZENER 1N756A	0300-20700
C85	CAP MICA 820P 10% 300V	1510-08210	CR37	DIODE 1N4151	0300-00400
C86	SELECTED VALUE (560P MICA TYP)		CR38	DIODE ZENER 1N756A	0300-20700
C87	CAP CER 33P 20% 50V	1500-03300	CR39	DIODE 1N4151	0300-00400
C88	CAP MICA 56P 10% 500V	1510-05600	CR40	DIODE 1N4151	0300-00400
C89	CAP VAR 5-18P DV11PS18A	1550-01800	CR41	DIODE REF 1N825A	0300-21100
C90	CAP CER 1n 20% 50V	1500-01020	CR42	DIODE 1N4151	0300-00400
C91	CAP CER .1 -20%+80% 50V	1500-01040	CR43	DIODE 1N4151	0300-00400
C92	CAP CER .1 -20%+80% 50V	1500-01040	K5	RELAY 1FA 5V	0900-01100
C93	CAP CER .1 -20%+80% 50V	1500-01040	Q60	TSTR 2N3904A	0400-01200
C94	CAP CER .1 -20%+80% 50V	1500-01040	Q61	TSTR 2N3904A	0400-01200
C95	CAP CER .1 -20%+80% 50V	1500-01040	Q62	TSTR 2N3904A	0400-01200
C96	CAP CER 10P 20% 50V	1500-01000	Q63	TSTR 2N2369A	0400-00900
C97	CAP CER .1 -20%+80% 50V	1500-01040	Q64	TSTR 2N3904A	0400-01200
C98	CAP CER .1 -20%+80% 50V	1500-01040	Q65	TSTR 2N3904A	0400-01200
C99	SELECTED VALUE		Q66	TSTR DN5566	0400-40500
C100	CAP CER .1 -20%+80% 50V	1500-01040	Q67	TSTR 2N5087	0400-01900
C101	SELECTED VALUE				
C102	CAP CER .1 -20%+80% 50V	1500-01040			

Table 8-4. Model 8021 Parts List - Pulse Generator Board Assembly (continued)

REF	DESCRIPTION	PART#	REF	DESCRIPTION	PART#
Q68	TSTRJ109	0400-02500	R206	RES MTF 4.99K 1%	0104-49910
Q69	TSTRJ109	0400-02500	R207	RES COMP 1K	0100-01020
Q70	TSTR2N3904A	0400-01200	R208	RES MTF 1.1K 1%	0104-11010
Q71	TSTR2N3904A	0400-01200	R209	RES COMP 22K	0100-02230
Q72	TSTR2N3904A	0400-01200	R210	RES COMP 22K	0100-02230
Q73	TSTR2N4392A	0400-40000	R211	RES VAR 1K 3386F	0203-01020
Q74	TSTR2N4392A	0400-40000	R212	RES MTF 10K 1%	0104-10020
Q75	TSTR2N3904A	0400-01200	R213	RES VAR 100 3386F	0203-01010
Q76	TSTR2N3904A	0400-01200	R214	RES COMP 10K	0100-01030
R180	RES COMP 1K	0100-01020	R215	RES COMP 3.3K	0100-03320
R181	RES COMP 1K	0100-01020	R216	RES MTF 10K 1%	0104-10020
R182	RES COMP 2.7	0100-02R70	R217	RES COMP 10K	0100-01030
R184	RES COMP 10K	0100-01030	R218	SELECTED VALUE	
R185	RES COMP 1K	0100-01020	R219	RES MTF 10K 1%	0104-10020
R186	RES COMP 1K	0100-01020	R220	RES COMP 22K	0100-02230
R187	RES COMP 1K	0100-01020	R221	RES COMP 3.3K	0100-03320
R188	RES VAR 200 3386F	0203-02010	R222	RES COMP 3.3K	0100-03320
R189	RES COMP 33	0100-03300	R223	RES COMP 3.3K	0100-03320
R190	RES MTF 20K 1%	0104-20020	R224	RES MTF 10K 1%	0104-10020
R191	RES COMP 100	0100-01010	R225	RES COMP 22K	0100-02230
R192	SELECTED VALUE (100 1% TYP)		R226	RES COMP 1K	0100-01020
R193	RES MTF 10K 1%	0104-10020	R227	RES COMP 1K	0100-01020
R194	RES COMP 1K	0100-01020	U30	IC 74HC4094	0520-07400
R195	SELECTED VALUE (100 1% TYP)		U31	IC 74F64	0500-12780
R196	RES MTF 2K 1%	0104-20010	U32	IC 74AC74	0505-00800
R197	RES COMP 100	0100-01010	U33	IC LM741E	0500-56300
R198	RES MTF 2.26K 1%	0104-22610	U34	IC AD9686BQ	0500-60700
R199	RES MTF 215 1%	0104-21500	U35	IC LM741C	0500-56310
R200	RES COMP 10K	0100-01030	U36	IC 10 BIT D/A AD7533JN	0560-00700
R201	RES MTF 1K 1%	0104-10010	U37	IC SHIFT REGISTER CD4094B	0540-01100
R202	RES COMP 22K	0100-02230	U38	IC SHIFT REGISTER CD4094B	0540-01100
R203	RES COMP 22K	0100-02230	U39	IC DUAL COMP LM318N	0500-53200
R204	RES COMP 22K	0100-02230	U40	IC DUAL COMP LM318N	0500-53200
R205	RES COMP 22K	0100-02230	U41	IC DUAL OP AMP LM1458N	0500-56500

Table 8-5. Model 8022 Parts List - AM Generator Board Assembly

REF	DESCRIPTION	PART#	REF	DESCRIPTION	PART#
C65	CAP CER .1 -20%+80% 50V	1500-01040	Q48	TSTR 2N5771	0400-00750
C66	CAP CER .1 -20%+80% 50V	1500-01040	Q49	TSTR 2N5771	0400-00750
C67	CAP CER .1 -20%+80% 50V	1500-01040	Q50	TSTR 2N5771	0400-00750
C68	CAP TANT 10 35V	1540-0106A	Q51	TSTR 2N3646	0400-00200
C69	SELECTED VALUE		Q52	TSTR 2N3646	0400-00200
C70	CAP CER .1 -20%+80% 50V	1500-01040	Q53	TSTR 2N3904A	0400-01200
C71	CAP CER .1 -20%+80% 50V	1500-01040	Q54	TSTR 2N3906A	0400-01340
C72	CAP CER 10n 20% 50V	1500-01030	R130	RES MTF 4.99K 1%	0104-49910
C73	CAP CER .1 -20%+80% 50V	1500-01040	R131	RES MTF 3.01K 1%	0104-30110
CR25	DIODE REF 1N825A	0300-21100	R132	RES COMP 1.2K	0100-01220
CR26	DIODE 1N4151	0300-00400	R133	RES MTF 4.99K 1%	0104-49910
CR27	DIODE 1N4151	0300-00400	R134	RES COMP 10K	0100-01030
CR28	DIODE ZENER 1N755	0300-20310	R135	RES VAR 2K 3386F	0203-02020
CR29	DIODE 1N4151	0300-00400	R136	RES MTF 1.78K 1%	0104-17810
K4	RELAY RZ-1	0900-00700	R137	RES MTF 5.62K 1%	0104-56210
L1	FERRITE BEAD 24 57-1355	4200-00000	R139	RES COMP 47K	0100-04730
L2	FERRITE BEAD 24 57-1355	4200-00000	R140	RES MTF 10K 1%	0104-10020
Q47	TSTR 2N5771	0400-00750	R141	RES MTF 4.99K 1%	0104-49910

Table 8-5. Model 8022 Parts List - AM Generator Board Assembly (continued)

<b>REF</b>	<b>DESCRIPTION</b>	<b>PART#</b>	<b>REF</b>	<b>DESCRIPTION</b>	<b>PART#</b>
R142	RESVAR 100K 3386F-1-104	0203-01040	R161	RESMTF 2.26K 1%	0104-22610
R143	RESMTF 49.9 1%	0104-49R90	R162	RES COMP 330	0100-03310
R144	RESMTF 49.9 1%	0104-49R90	R163	RES COMP 10	0100-01000
R145	RESMTF 909 1%	0104-90900	R164	RESMTF 100 1%	0104-10000
R146	RESMTF 909 1%	0104-90900	R165	RESMTF 100 1%	0104-10000
R147	RESMTF 49.9 1%	0104-49R90	R166	RES COMP 330	0100-03310
R148	RESMTF 100 1%	0104-10000	R167	RES COMP 10	0100-01000
R149	RESMTF 100 1%	0104-10000	R169	RES COMP 470	0100-04710
R150	RES COMP 2.7	0100-02R70	R170	RESMTF 10K 1%	0104-10020
R151	RES COMP 2.7	0100-02R70	R171	RESMTF 5.62K 1%	0104-56210
R152	RESMTF 2.26K 1%	0104-22610	R172	RESMTF 499 1%	0104-49900
R153	RES COMP 47	0100-04700	R173	RESMTF 402 1%	0104-40200
R155	RESMTF 100 .25%	0106-10000	R174	RES VAR 1K 3386F	0203-01020
R156	RESMTF 100 .25%	0106-10000	U218	IC SHIFT REGISTOR CD4094B	0540-01100
R157	RES COMP 33	0100-03300	U22	IC 10 BIT D/A AD7533JN	0560-00700
R158	RES COM 510 1/2W	0101-05110	U23	IC OP AMP CA3140E	0500-57200
R159	RES VAR 10 33867F	0203-01000	U24	IC TRANS ARRRA Y CA3054	0500-57600
R160	RES COMP 22	0100-02200	U25	IC TRANS ARRRA Y CA3054	0500-57600

This page was intentionally left blank

---

---

**SECTION 9**  
**SCHEMATIC DRAWINGS**

List Of Figures

Figure	Description	Page
9-1	Main Board - Power Supply	9-1
9-2	Main Board - C.P.U	9-2
9-3	Main Board - VCO and Sine Shaper	9-3
9-4	Main Board - Current Generator	9-4
9-5	Main Board - Components Location	9-5
9-6	Keyboard and Display	9-6
9-7	Keyboard and Display - Components Location	9-7
9-8	8020 Final Amplifier Board - Part 1	9-8
9-9	8020 Final Amplifier Board - Part 2	9-9
9-10	8020 Final Amplifier Board - Components Location	9-10
9-11	8021 Pulse Generator Section	9-11
9-12	8021 Pulse Generator Section - Components Location	9-12
9-13	8022 AM Generator Section	9-13
9-14	8022 AM Generator Section - Components Location	9-14
9-15	Exploded View	9-15
9-16	Rack Mount Assembly	9-16

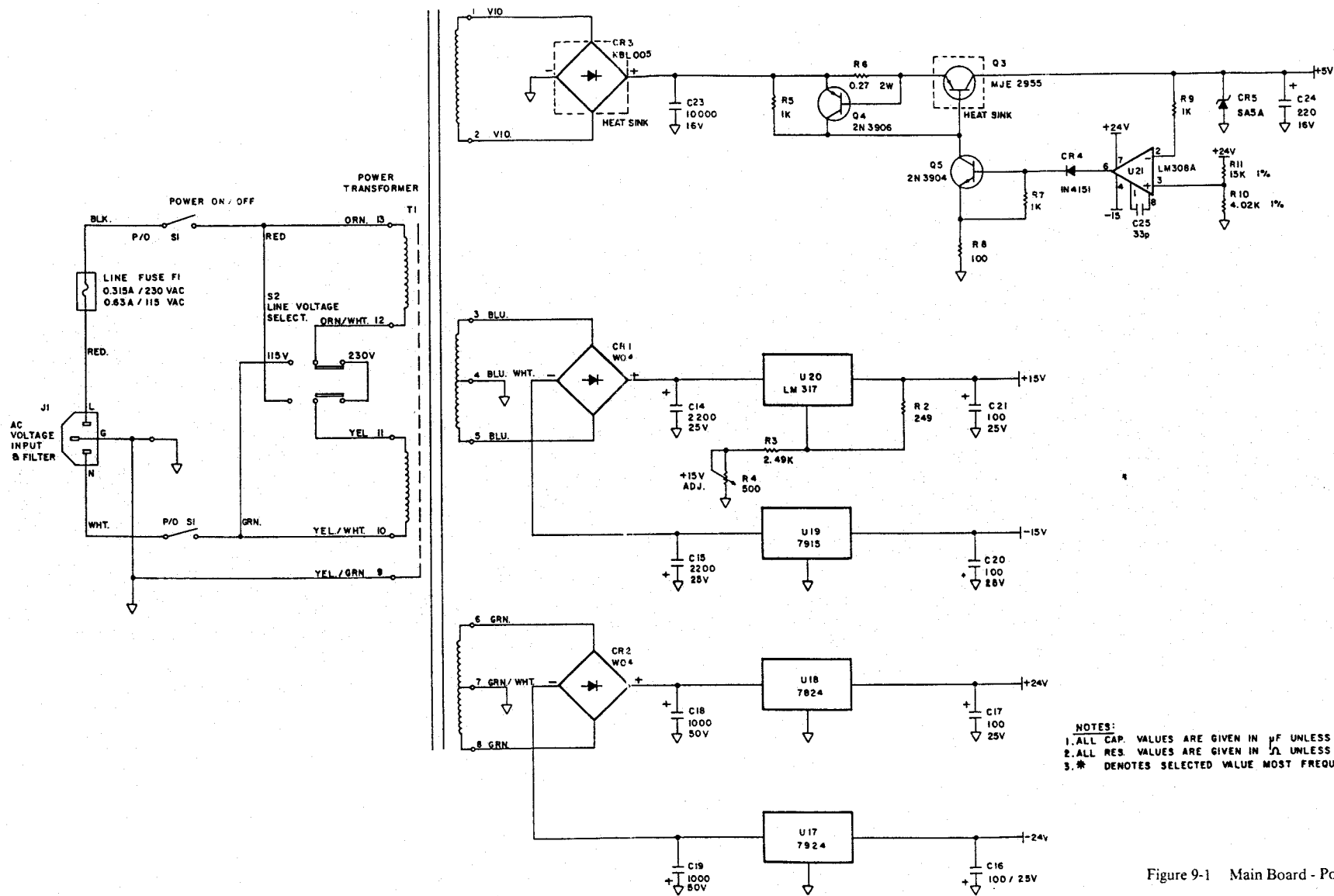

NOTES:  
 1. ALL CAP. VALUES ARE GIVEN IN  $\mu$ F UNLESS OTHERWISE NOTE!  
 2. ALL RES. VALUES ARE GIVEN IN  $\Omega$  UNLESS OTHERWISE NOTE!  
 3. \* DENOTES SELECTED VALUE MOST FREQUENT VALUE SHOWN!

Figure 9-1 Main Board - Power Supply





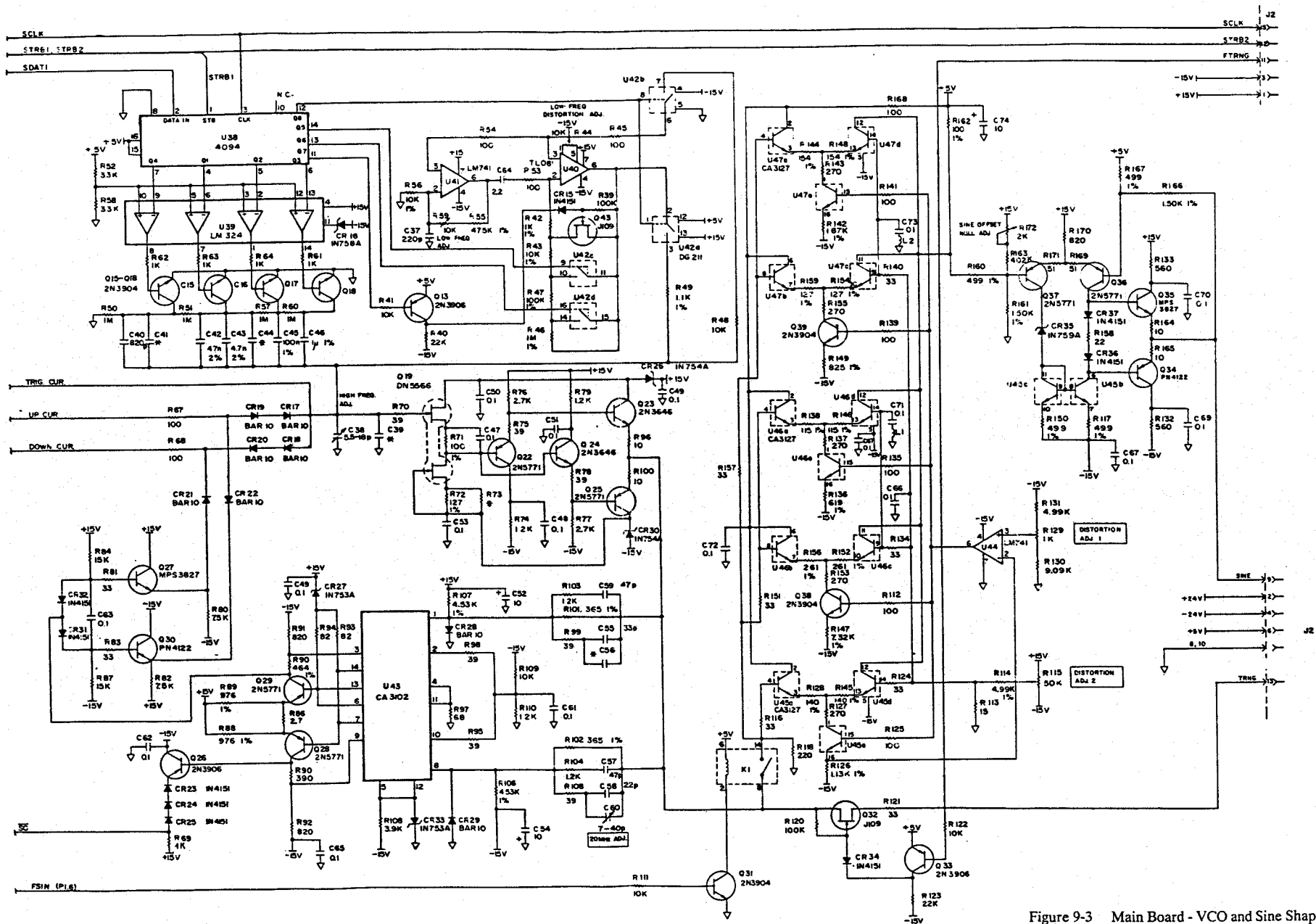

NOTES:  
 1. ALL CAP. VALUES ARE GIVEN IN pF UNLESS OTHERWISE NOTED.

Figure 9-3 Main Board - VCO and Sine Shaper

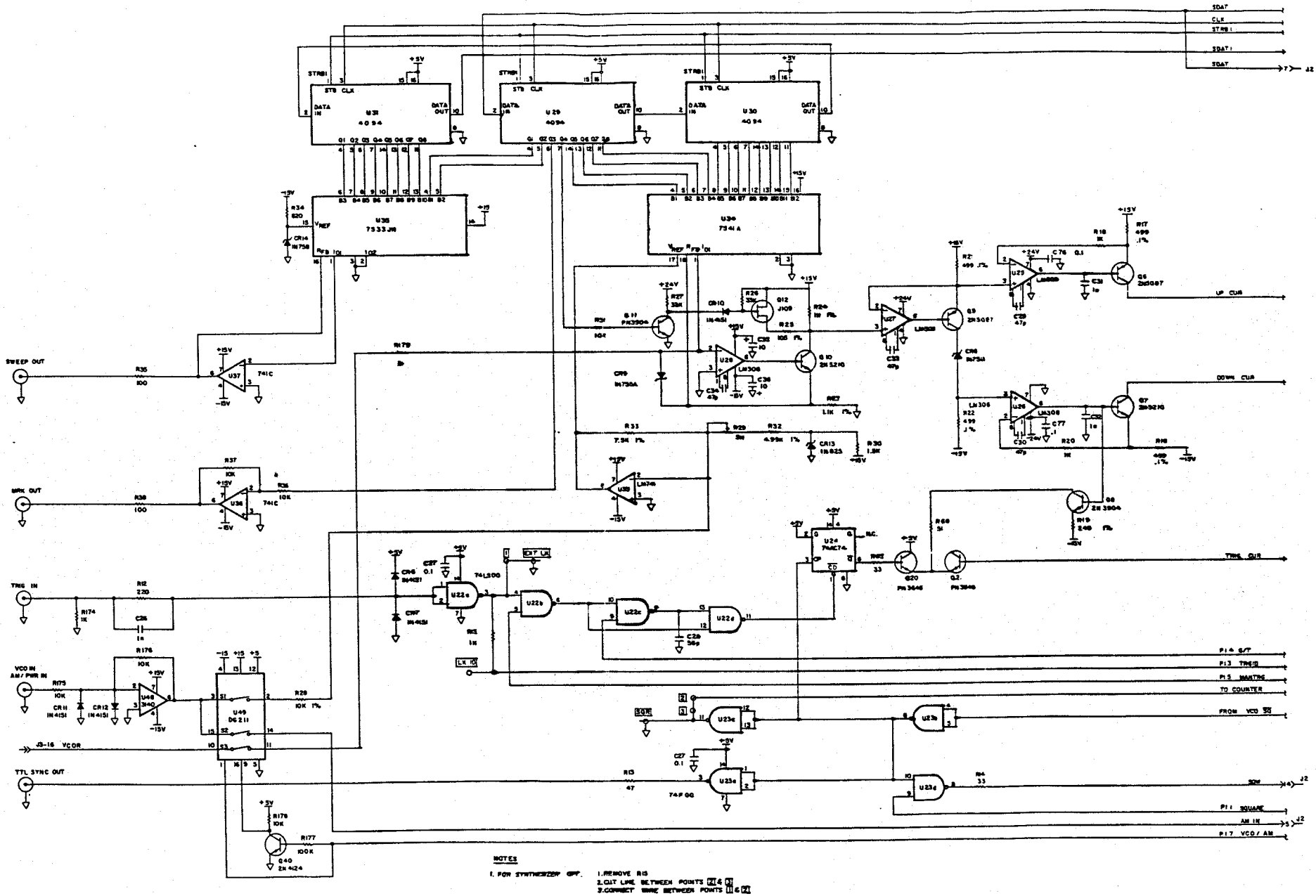

NOTES  
 1. FOR SYNTHESIZED OFF. 1. REMOVE R18  
 2. CUT LINE BETWEEN POINTS [2] & [3]  
 3. CONNECT WIRE BETWEEN POINTS [1] & [2]

Figure 9-4 Main Board - Current Generator

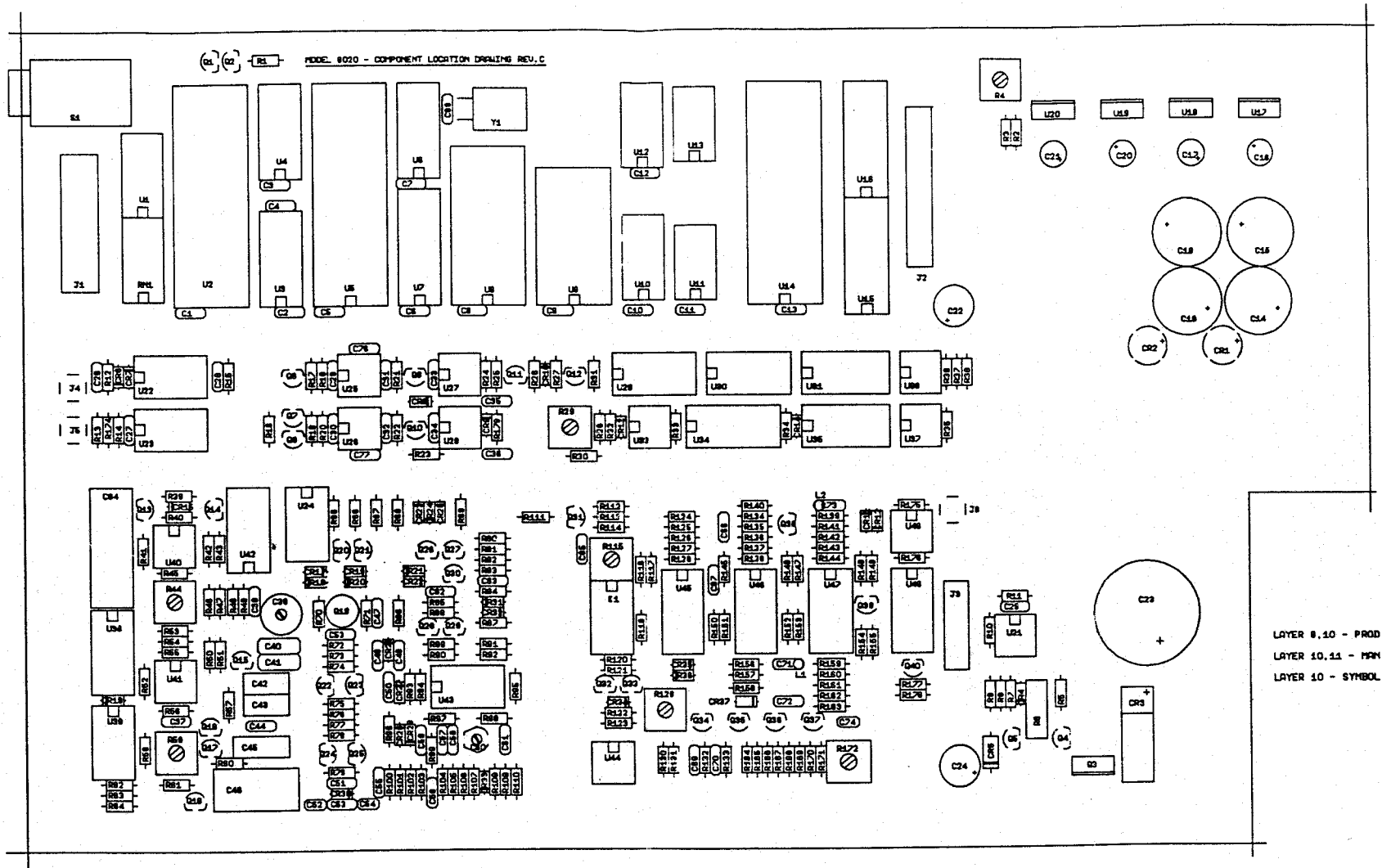

Figure 9-5 Main Board - Components Location

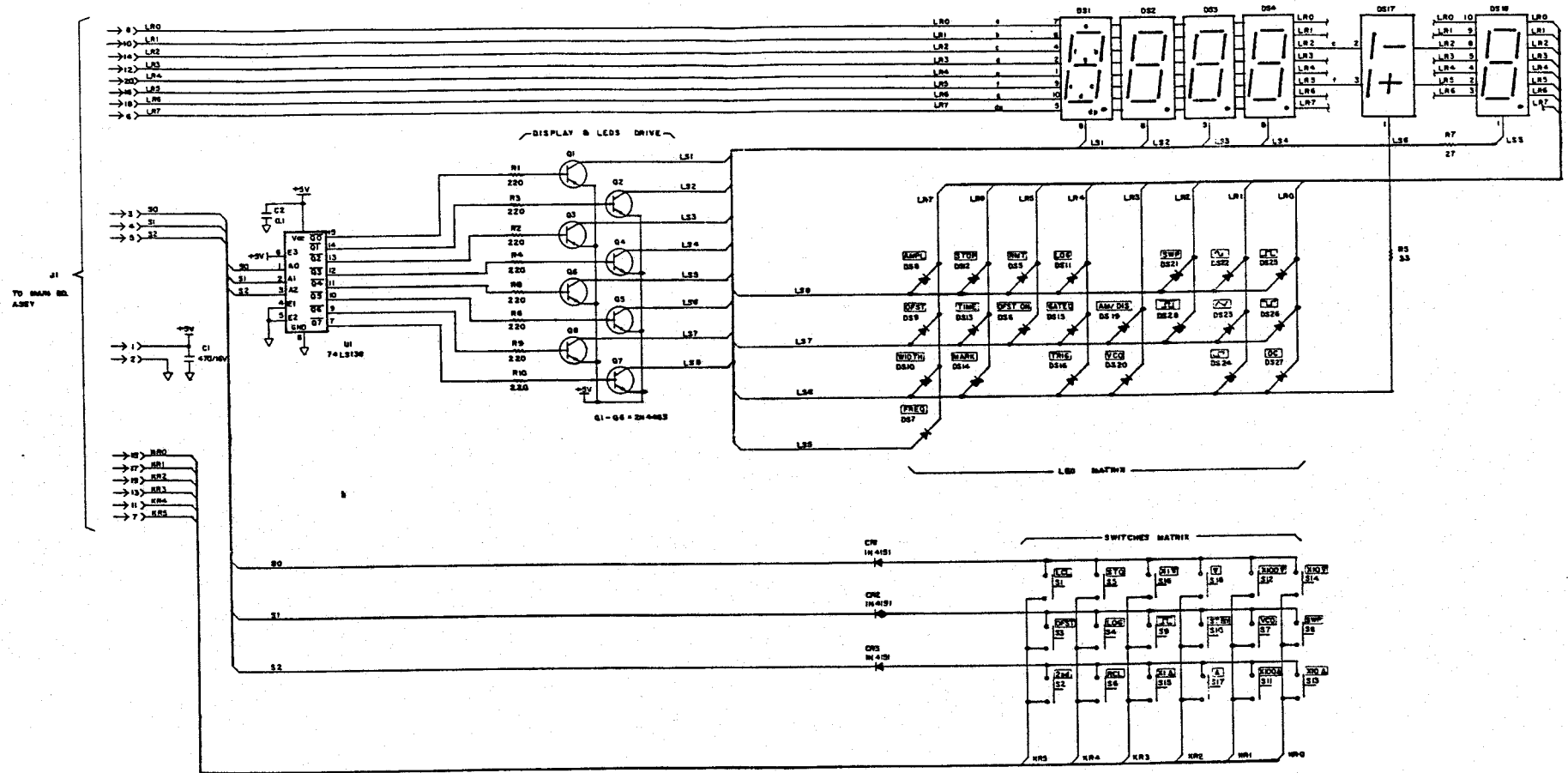

Figure 9-6 Keyboard and Display

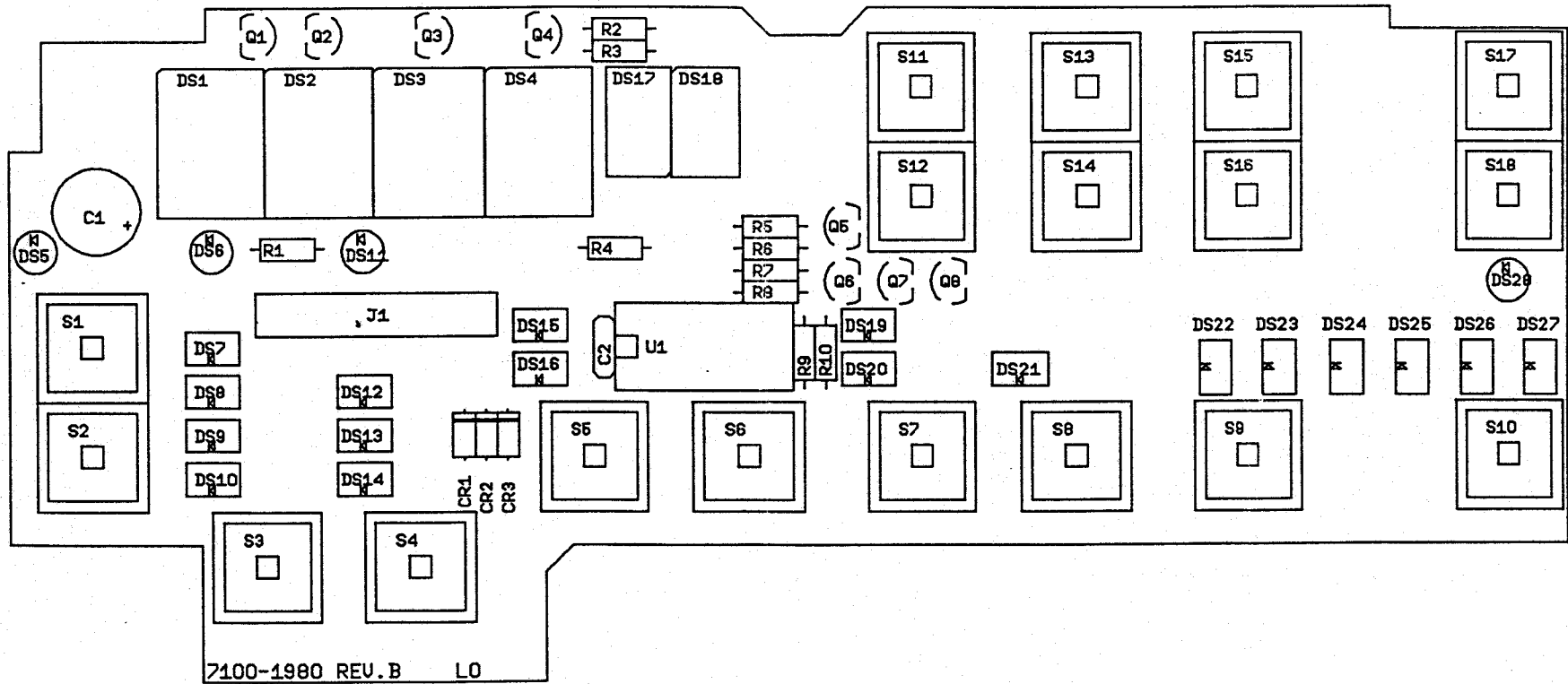

Figure 9-7 Keyboard and Display - Components Location

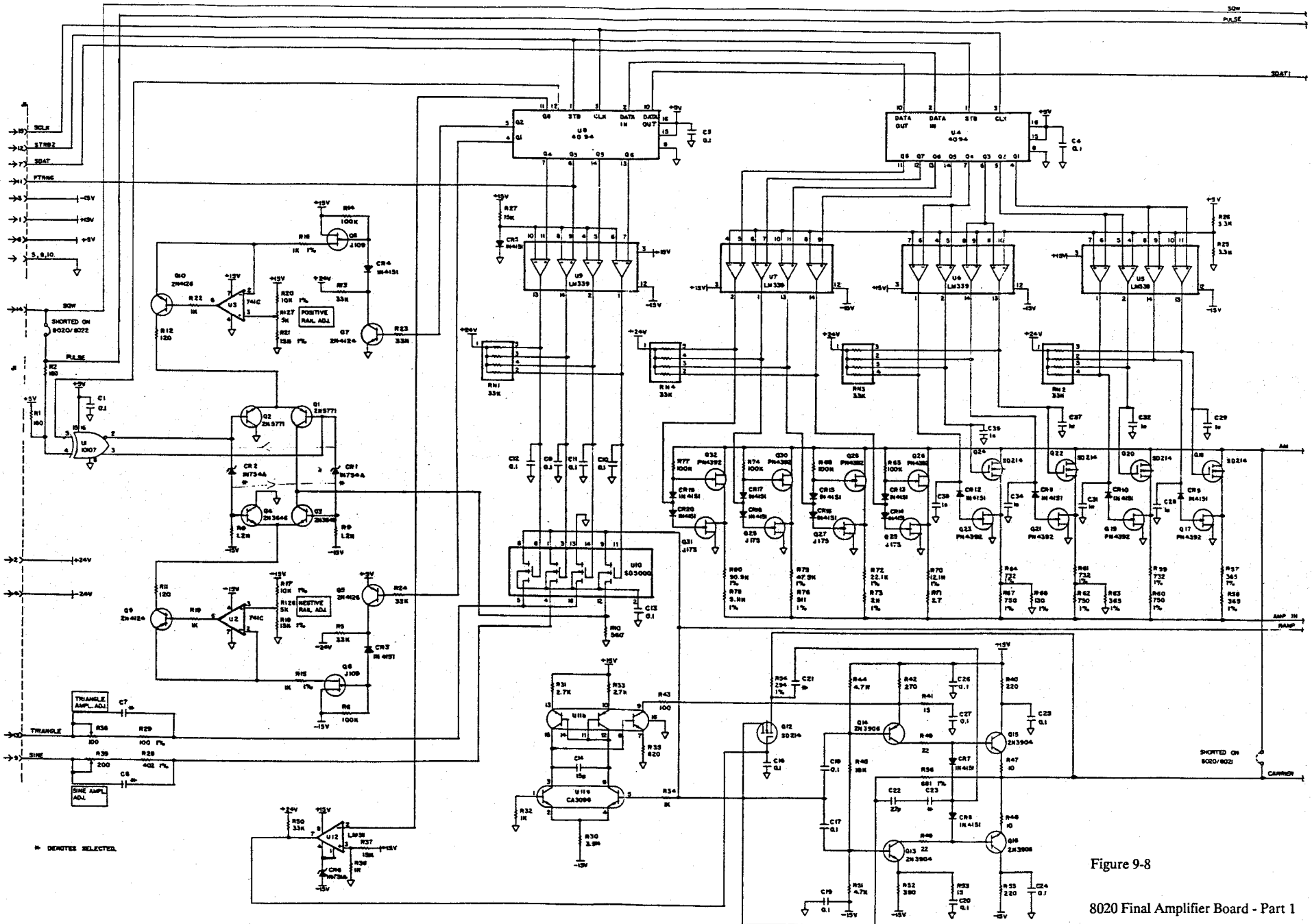

Figure 9-8  
8020 Final Amplifier Board - Part 1

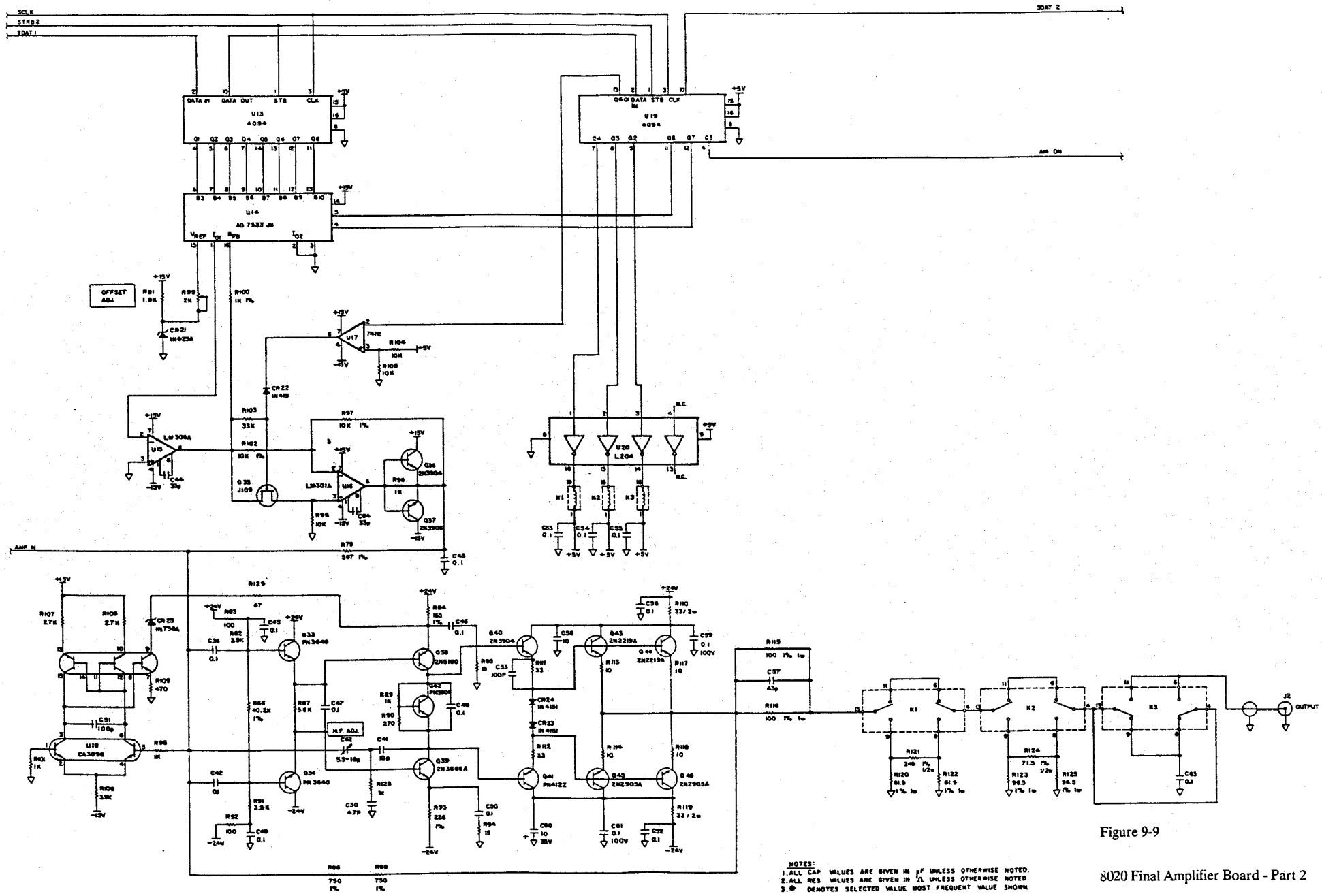
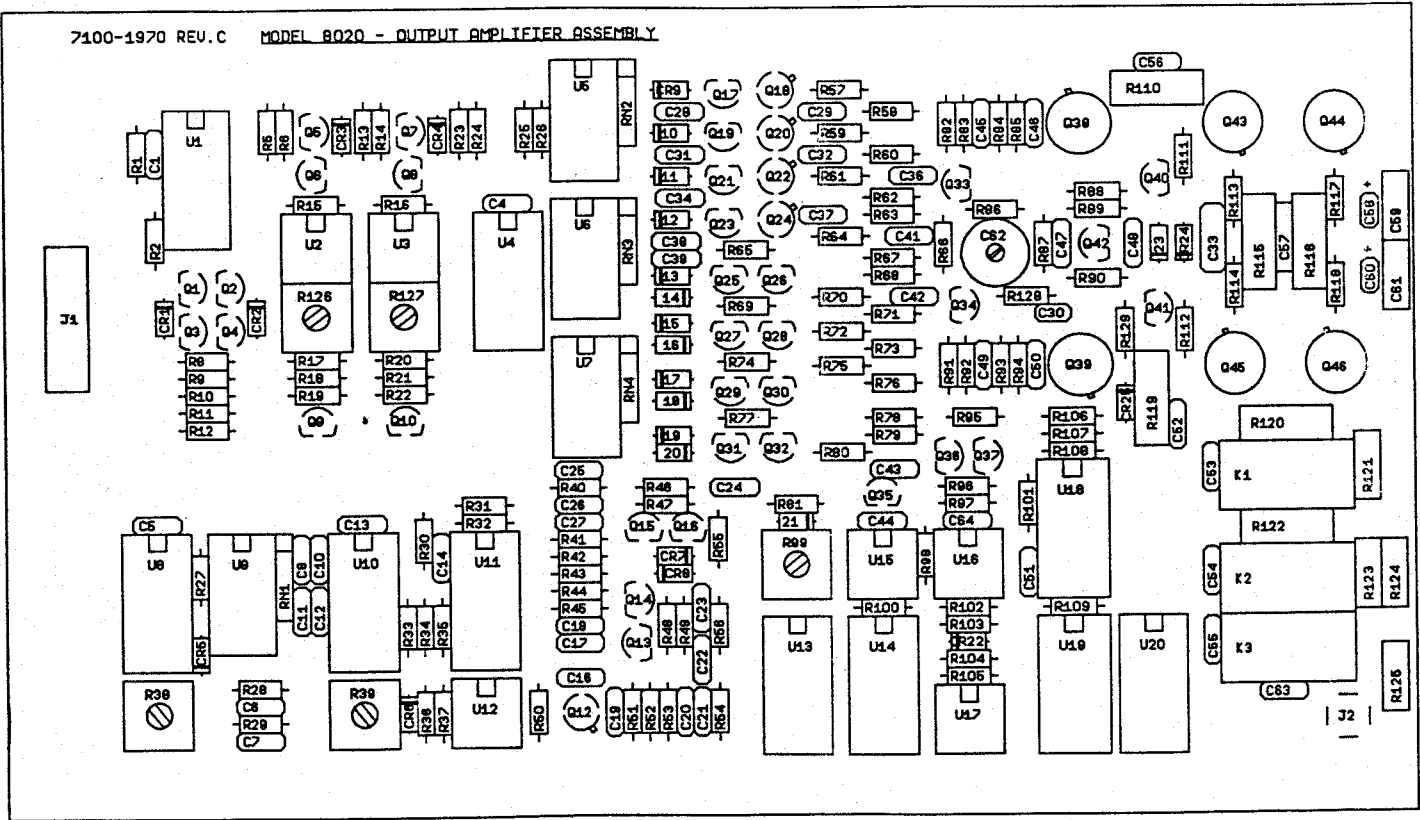

Figure 9-9

7100-1970 REV.C MODEL 8020 - OUTPUT AMPLIFIER ASSEMBLY



- NOTES:
1. ALL CAP. VALUES ARE GIVEN IN  $\mu$ F UNLESS OTHERWISE NOTED.
  2. ALL RES. VALUES ARE GIVEN IN  $\Omega$  UNLESS OTHERWISE NOTED.
  3. \* DENOTES SELECTED VALUE MOST FREQUENT VALUE SHOWN.

Figure 9-10 8020 Final Amplifier Board - Components Location



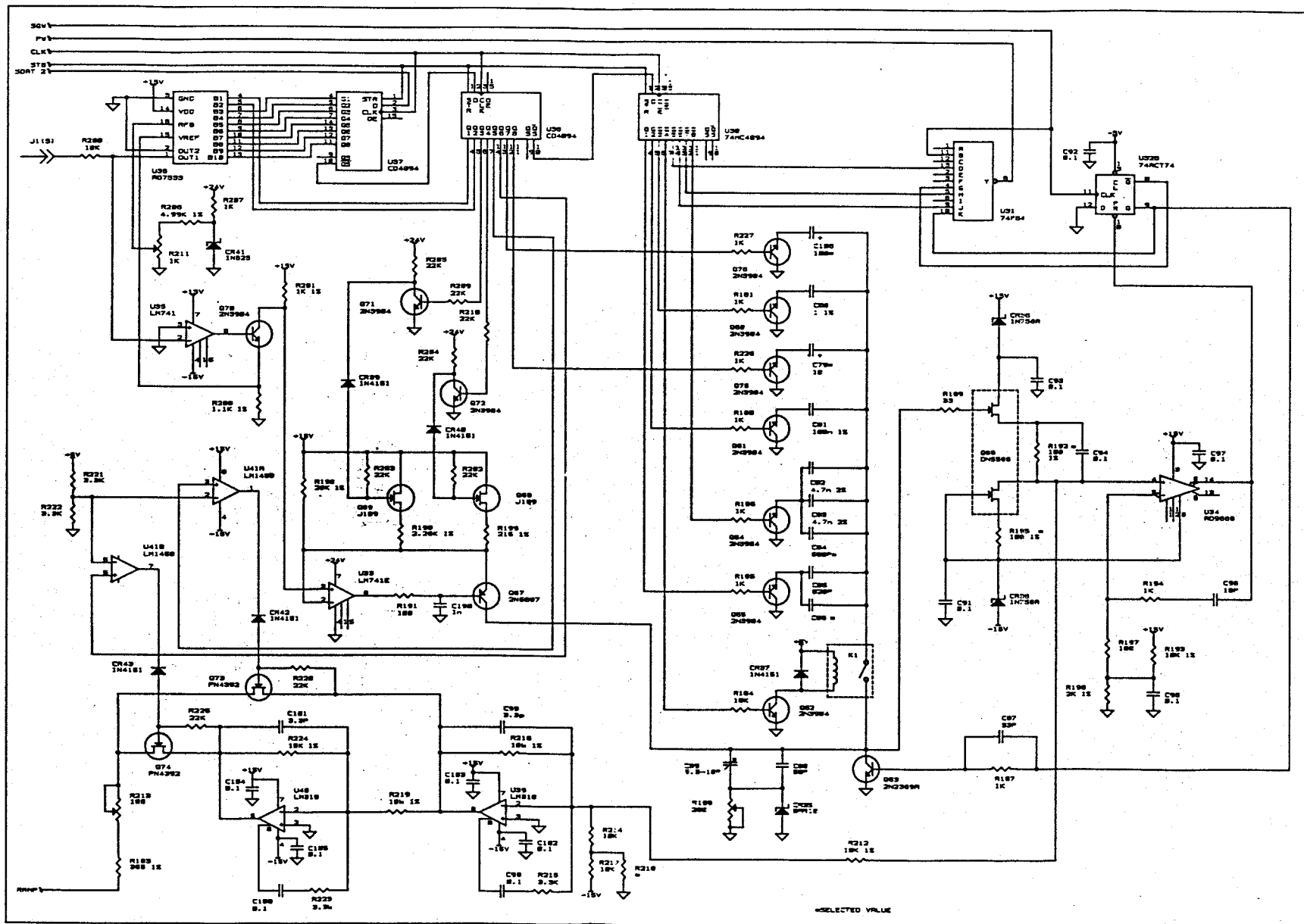
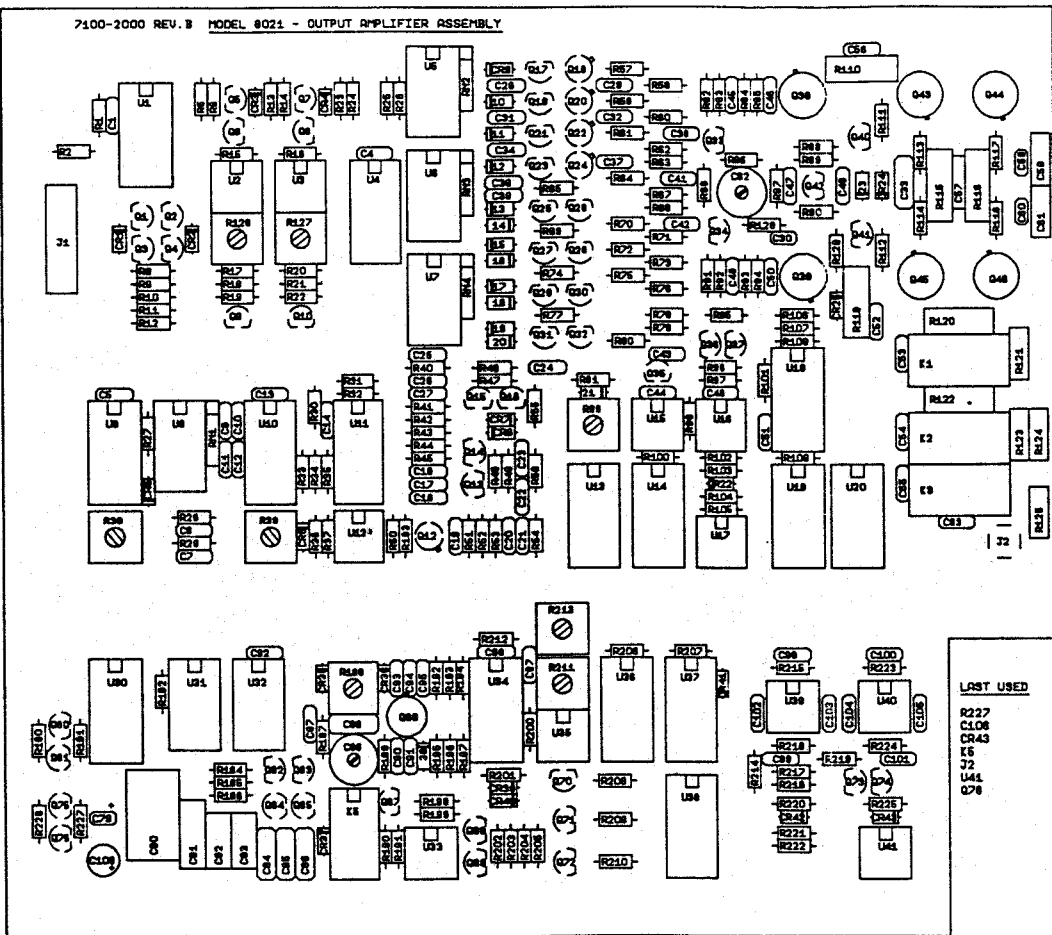

Figure 9-11 8021 Pulse Generator Section

7100-2000 REV. B MODEL 8021 - OUTPUT AMPLIFIER ASSEMBLY



NOTES:

1. ALL CAP VALUES ARE GIVEN IN  $\mu$ F UNLESS OTHERWISE NOTED.
2. ALL RES VALUES ARE GIVEN IN  $\Omega$  UNLESS OTHERWISE NOTED.
3. \* DENOTES SELECTED VALUE MOST FREQUENT VALUE SHOWN.

Figure 9-12 8021 Pulse Generator Section - Components Location

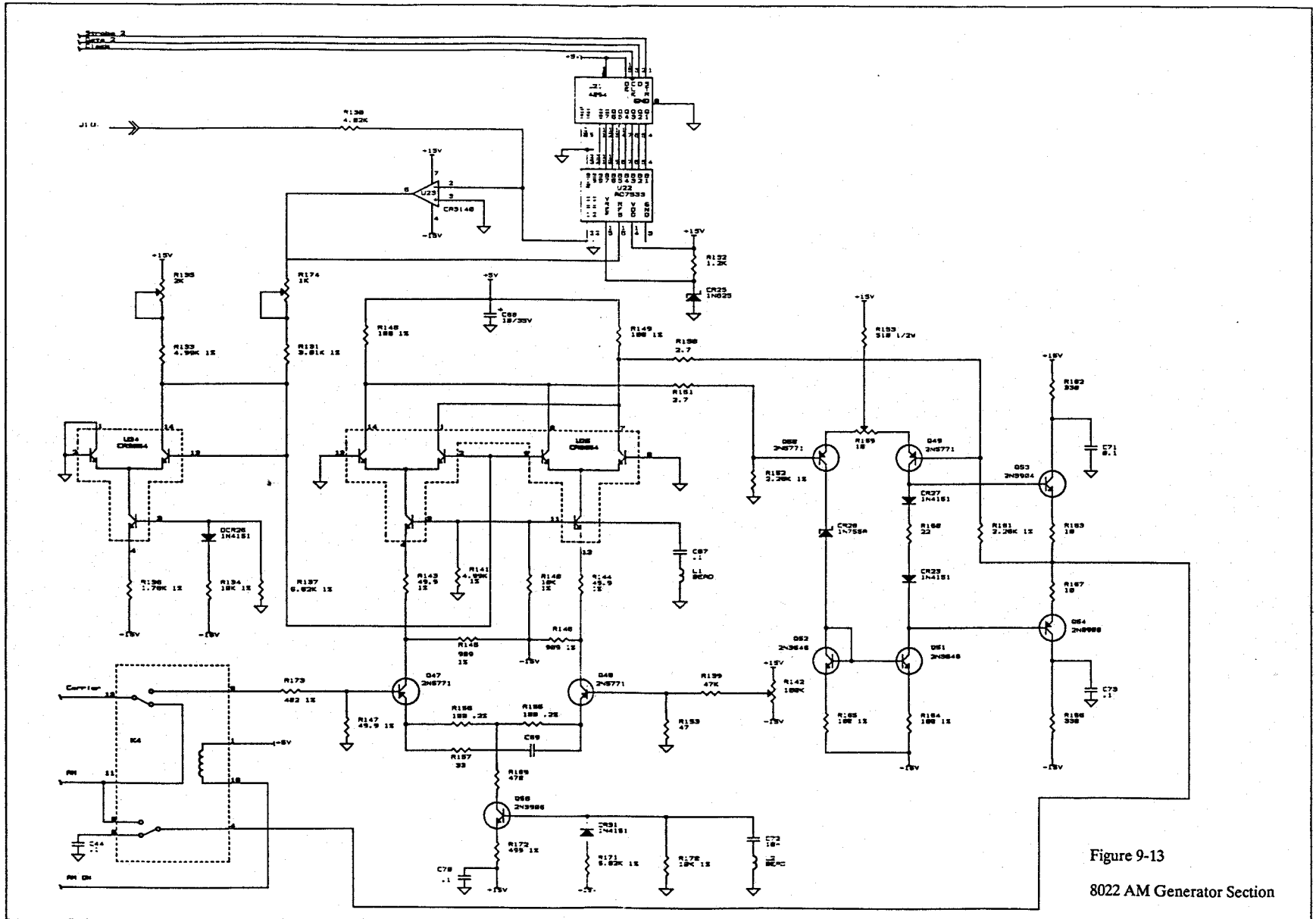
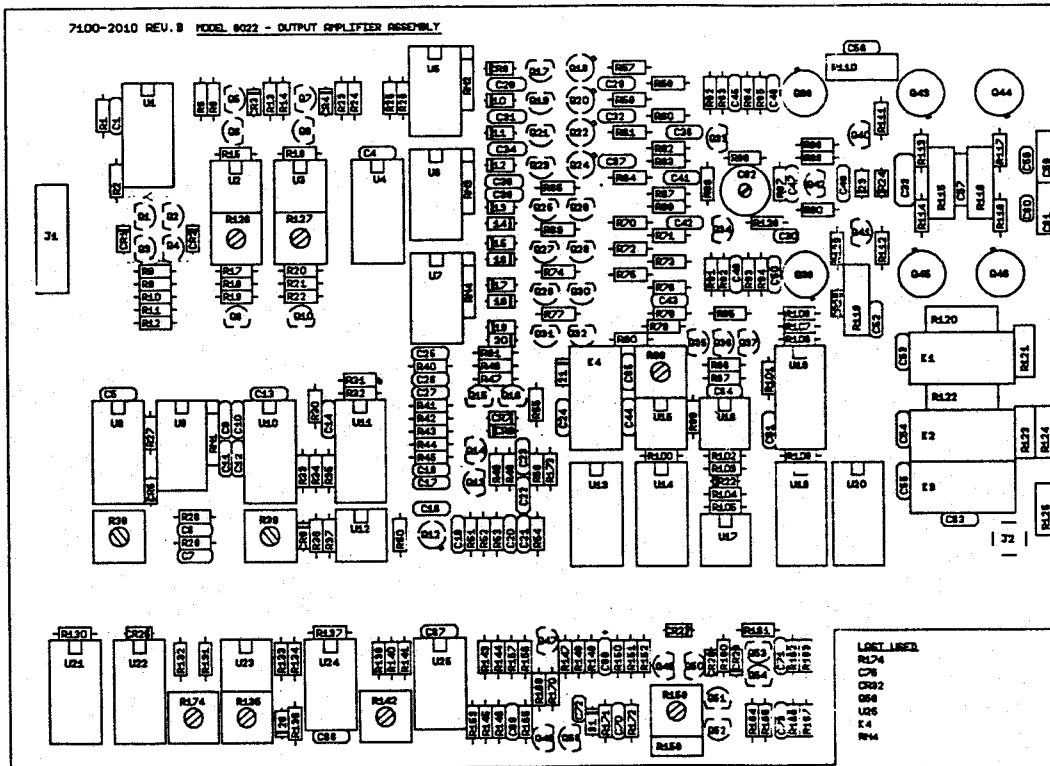

Figure 9-13  
8022 AM Generator Section



- NOTES:
1. ALL CAP VALUES ARE GIVEN IN  $\mu$ F UNLESS OTHERWISE NOTED.
  2. ALL RES VALUES ARE GIVEN IN  $\Omega$  UNLESS OTHERWISE NOTED.
  3. \* DENOTES SELECTED VALUE MOST FREQUENT VALUE SHOWN.

Figure 9-14 8022 AM Generator Section - Components Location

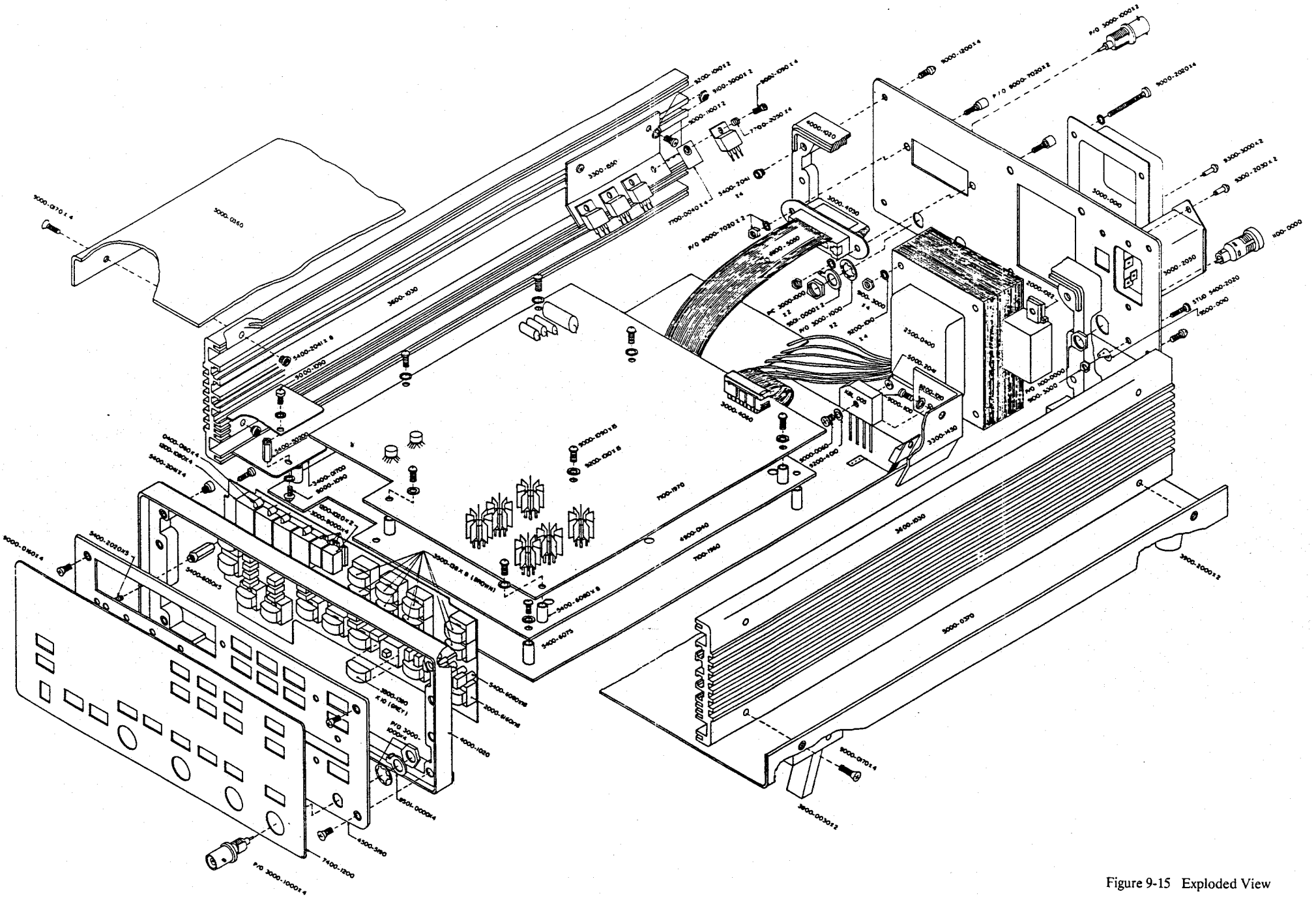

Figure 9-15 Exploded View

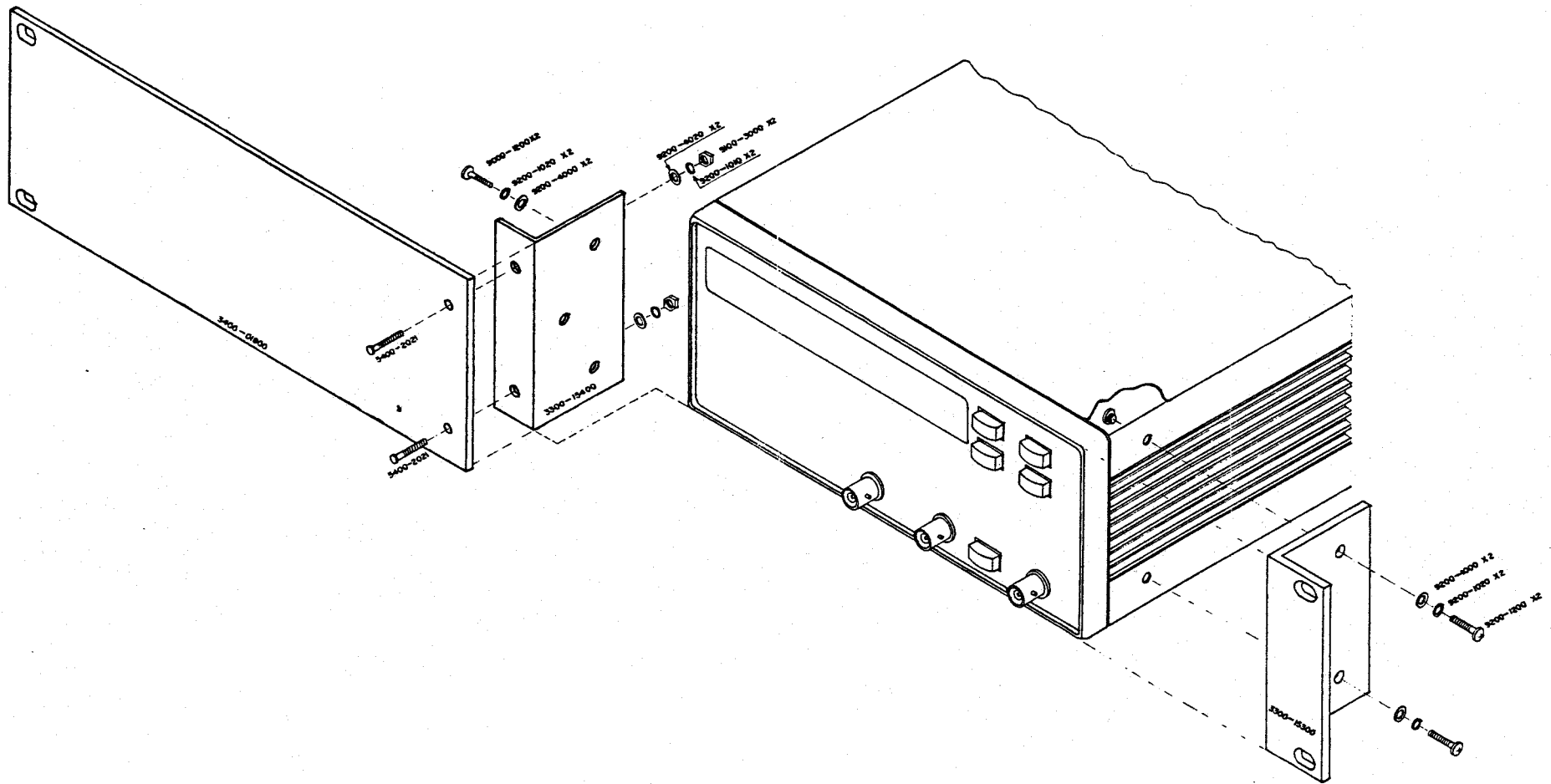

Figure 9-16 Rack Mount Assembly